

**2011
FIRESTONE INDY LIGHTS® SERIES
RULE BOOK**

TABLE OF CONTENTS

PREFACE	1
Definitions	1
I. GENERAL	7
1.1 Governance	7
1.2 Safety	12
1.3 Emblem Display on Uniforms, Cars and ..	19
Other Equipment	27
1.4 Advertising	27
1.5 Product Use	27
1.6 Event Personnel and Operations	29
II. MEMBERSHIP	33
2.1 General.....	33
2.2 Application.....	33
2.3 Term.....	34
2.4 Interim Review of Qualifications	34
2.5 Acknowledgement of Release and Assumption of Risk.....	35
2.6 Applicable Laws and Jurisdiction	35
2.7 Conduct Identification	36
2.8 Litigation.....	36
2.9 Categories	36
2.10 Age	37
2.11 Moral Fitness	37
2.12 Physical and Psychological Fitness.....	37
2.13 Medical Examinations and Treatment.....	38
2.14 Fitness to Participate	39
2.15 Substance Abuse	39
2.16 Violation of Laws	40
2.17 Medical Records	40
2.18 Memberships, Licenses and Credentials ...	40

III. SANCTIONS/GOVERNING	43
3.1 Promotion of Events.....	43
3.2 Event Promoter Responsibilities	43
3.3 Restrictions	43
IV. ENTRANT / DRIVER LICENSING AND FREQUENCY / CAR REGISTRTION.....	45
4.1 General.....	45
4.2 Entrant and Driver Licensing	46
4.3 Radio & Wireless Frequency Registration	51
4.4 Car Registration	53
V. ENTRIES.....	61
5.1 General.....	61
5.2 Fee	62
5.3 Deadline	62
5.4 Electronic Entries.....	62
5.5 Reopening of Entries.....	62
5.6 Failure to Participate	63
5.7 Entry Change	63
VI. TESTING.....	65
6.1 In General	65
6.2 Approved Testing.....	65
6.3 Additional Testing Restrictions.....	68
VII. ON TRACK PROCEDURES.....	69
7.1 General.....	69
7.2 Timing and Scoring.....	77
7.3 Pit Assignments, Pit Equipment, Pit Personnel Pit Access, Pit Procedures, and Pit Penalties.....	80
7.4 Pre-Race.....	82
7.5 Race Start.....	82
7.6 Race Restart	84
7.7 Hazardous Mechanical Conditions.....	85
VIII. QUALIFICATIONS.....	87
8.1 All Events	87

8.2	Oval Events.....	92
8.3	Road/Street Course Events.....	96
IX.	PENALTIES	99
9.1	General.....	99
9.2	Scope of Penalties	99
9.3	Additional Provisions and Guidelines	103
X.	CHAMPIONSHIPS, POINTS, AND POINT FUNDS	105
10.1	Championships and Point Standings	105
10.2	Significance of the Car Number.....	105
10.3	Crediting of Points	105
10.4	Ties	106
10.5	End of Season Points Fund	106
10.6	Points	106
XI.	AWARDS.....	107
11.1	Approval	107
11.2	Awards	107
11.3	Withholding	107
XII.	PROTESTS	109
12.1	Submission of Protests	109
12.2	Protest	109
12.3	Right to Protest and Time Limits	109
12.4	Jurisdiction.....	113
12.5	Advisory Committee	113
12.6	Hearing of the Protest	113
12.7	Compliance with Procedure	114

XIII. APPEALS	115
13.1 Initiation of an Appeal	115
13.2 Jurisdiction.....	115
13.3 Advisory Committee	116
13.4 Hearing of the Appeal	116
13.5 Conduct of the Appeal Hearing.....	116
13.6 Structure of the Appeal Hearing.....	117
13.7 Powers of the Senior Official	118
13.8 Determination of the Appeal	119
13.9 Appeal Procedure Final.....	119
13.10 Compliance with Procedures.....	120
XIV. TECHNICAL SPECIFICATIONS	121
14.1 General.....	121
14.2 Inspections	123
14.3 Car Size, Car Weight and Driver Equivalency Weight.....	126
14.4 Chassis	127
14.5 Aerodynamics	142
14.6 Suspension	144
14.7 Suspension Wheel/Wing Energy Management System (SWEMS)	151
14.8 Brake Ducts, Brake Lines and Brakes....	154
14.9 Wheels	154
14.10 Tires	154
14.11 Engine	155
14.12 Transmission.....	160
14.13 Chassis Electronics	163
14.14 Fuel-Air.....	165
14.15 Pit Lane/Garage Area Fire Equipment ..	165
14.16 Equipment.....	165

© 2010 INDYCAR

**2011
FIRESTONE INDY LIGHTS
RULE BOOK**

PREFACE

The Rules apply to the 2011 Firestone Indy Lights Events. Each Member has been provided with or has been given access to a copy of the Rules, is deemed to have a full awareness and understanding of the Rules, and has agreed to abide by and be personally responsible for compliance with, the Rules. Further information may be obtained by contacting the INDYCAR offices at 4565 West 16th Street, Indianapolis, IN 46222, Telephone (317) 492-6526.

Definitions

Terms used in the Rules shall have the following meanings:

ACCUS-FIA -. The Automobile Competition Committee of the United States (“ACCUS”) is the National Sporting Authority of the Federation (“ASN”) Internationale de l’Automobile (“FIA”) for the United States. ACCUS is comprised of the seven major motorsports sanctioning/governing organizations (known by or within the FIA as “member clubs”): Grand Am, IMSA, INDYCAR, NASCAR, NHRA, SCCA and USAC. ACCUS is the liaison between the member clubs, other ASNs and the FIA. ACCUS prepares listings on the international calendar, issues international motorsport licenses to U.S. and foreign citizens living in the U.S., issues authorizations for foreign participation, and certifies and maintains U.S. and international records.

Associate – The firm(s), corporation(s) or other business association(s) named on an Associate’s membership application approved by INDYCAR, remaining in good standing, and uniquely identified by a tax identification

number. Associate includes Associate and Associate's officers, directors, members, owners, successors, assigns, agents, employees, representatives, and affiliates. Associate includes Manufacturers. Associate is responsible for Associate Participants and Associate guests.

Car – A four-wheel automotive vehicle consisting of the combination of chassis, Engine, transmission, and tires. The vehicle must be supplied by Manufacturers, approved by INDYCAR, and conform to the specifications, spirit, and illustrations in, and intent of, the Rules.

Competitor - A Driver, Entrant, crew member, Manufacturer or any other individual or entity who is a Member and participates competitively in an Event.

discretion - Refers to the exercise by Officials of their judgment in making a determination as to the application, construction and interpretation of the Rules.

Driver - The individual named on a Driver's License and membership application approved by INDYCAR and issued by ACCUS-FIA (or another ASN, if applicable) and remaining in good standing. Driver is responsible for Driver guests.

ECU - Engine Control Unit.

Engine - An engine provided by the engine builder and approved by INDYCAR. Unless otherwise approved by INDYCAR, all engines must be of the same specification and used without modification.

Entrant - The firm(s), corporation(s) or other business association(s) named on an Entrant's License and membership application approved by INDYCAR and issued by ACCUS-FIA, remaining in good standing, and uniquely identified by a Car number. Entrant includes Entrant and Entrant's officers, directors, members, owners, successors, assigns, agents, employees, representatives, and affiliates. Entrant is responsible for Entrant Participants and Entrant guests.

Entry - An Entrant's Car and Driver combination on an Entry form displaying the Entrant's Car number and approved by INDYCAR for participation in a designated Event.

Event - Any and all INDYCAR-officially governed functions or other INDYCAR-approved activities as the context shall require including without limitation promotions, compatibility tests, exhibitions, testing, registration, inspections, practice, qualifications, Race, pre- and post-Race ceremonies and activities and awards and ceremonies. Event does not include any IZOD IndyCar Series, STAR Mazda Championship Presented by Goodyear or USF2000 National Championship events, as those events are covered by separate rules.

Event Agreement - The agreement in effect between INDYCAR and an Event Promoter regarding the conduct of a Race Event.

Event Promoter - The firm(s), corporation(s) or other business association(s) named on an Event Agreement with INDYCAR and responsible for designated operations of an Event. Event Promoter includes Event Promoter and Event Promoter's officers, directors, members, owners, successors, assigns, agents, employees, representatives, and affiliates.

Firestone Indy Lights - Firestone Indy Lights operated by INDYCAR. Indy Lights (and design) are registered trademarks of Brickyard Trademarks, Inc., used with permission. Firestone is a registered trademark of Bridgestone Americas Tire Operations, LLC, used with permission. Any reference in the Rules to Firestone Indy Lights may include INDYCAR and any reference to INDYCAR may include a reference to Firestone Indy Lights, if the context so requires.

Headings – The subject headings are included for purposes of convenience only, and shall not affect the construction or interpretation of any of the Rules.

INDYCAR- Indy Racing League, LLC d/b/a INDYCAR which owns and operates Firestone Indy Lights. "Indy Racing

League®," and "INDYCAR" are registered trademarks with the United States Patent and Trademark Office and cannot be used without authority from INDYCAR or Brickyard Trademarks, Inc.

License - An authorization approved by INDYCAR and issued by ACCUS-FIA (or another ASN, if applicable) to an individual or other entity to participate in an Event as a Driver, Entrant or Official.

Manufacturer - The firm(s), corporation(s) or other business association(s) named on an Associate's membership application approved by INDYCAR, remaining in good standing, and uniquely identified by a tax identification number. Manufacturer includes the approved chassis, tire, Engine and transmission manufacturers and their officers, directors, members, owners, successors, assigns, agents, employees, representatives, and affiliates. Manufacturer is responsible for Manufacturer Participants and Manufacturer guests.

Member - An individual, firm, corporation or other business association completing an INDYCAR membership application, receiving an acknowledgment of acceptance of such application from INDYCAR, and remaining in good standing. Without limitation, each Competitor and Official must be a Member. Member is responsible for Member's Participants and Member's Guests.

Officials - Any and all authorized INDYCAR officers, employees, agents, representatives, and subcontractors. Officials specifically referenced in the Rules include:

"CEO", Randy Bernard

"Senior Official", Brian Barnhart

"Race Director", Tony Cotman

The CEO, Senior Official and/or Race Director may replace any Official with another Official(s) at any time. The above-

named Officials may delegate their authority in whole or in part to another Official(s) at any time.

Participant - Any individual or entity along with their officers, directors, members, owners, successors, assigns, agents, employees, representatives, and affiliates that are in any way associated or connected with the Event facility or Event including but not limited to Event facility owners, Event Promoters, municipalities, racing associations, sanctioning/governing organizations, series organizers, Officials, Track workers, volunteers, Entrants, Car owners, Drivers, pit crew members, safety crew members, medical/rescue personnel, sponsors, manufacturers, suppliers, designers, advertisers, inspectors, construction contractors, engineers, architects, insurers, and all individuals in a restricted area.

Race - The feature activity of a Firestone Indy Lights race weekend.

Racing Surface - The area designated by the Race Director as eligible for use during competition. It may be formed by boundaries such as a wall or a line. It does not include grass or runoff areas.

Registration - The unique identity number assigned to a specific Car by the chassis Manufacturer.

Rules - This 2011 Firestone Indy Lights Rule Book, including all illustrations, supplementary rules, operations manuals, and bulletins issued by Officials, whether containing rules applicable only to a particular Event(s) or containing rules of general applicability. The Rules are made available in both hard copy and electronic format. Because of the ability to alter the electronic format, the hard copy issued by INDYCAR controls as to any discrepancies. Notwithstanding the foregoing, Rules may be issued verbally in mandatory meetings such as drivers meetings held during Events.

Safety Car – The official safety car approved by INDYCAR, driven by an Official and used during on-track activities.

Team - One or more Entrants under common ownership and/or control as determined by INDYCAR in its discretion.

Track - The area including without limitation the Racing Surface, pit entrance lanes, pit lane, and pit exit lanes located between the outer and innermost retaining walls.

I. GENERAL

1.1 Governance -

A. General –

(1) The Rules govern 2011 Firestone Indy Lights Events and supersede all previous rules, bulletins and supplementary rules and regulations, except as otherwise indicated.

(2) Each Member is personally responsible for the Member's compliance with the Rules.

(3) Officials may penalize any Member and/or exclude any Member or equipment from any Event if Officials deem any act or any condition to be hazardous and/or not meeting the specifications, spirit, illustrations, and intent of, the Rules. Conditions that may warrant penalty and/or exclusion include without limitation any action which an Official deems to be a threat to the integrity of INDYCAR, Firestone Indy Lights and/or orderly conduct of the Event and/or which relates to the design and construction of a Car or repairs to a damaged Car.

(4) If the Rules do not expressly permit a variation, then the Member shall presume that such variation is not permitted. If a Member is uncertain if an act, part, etc. violates a Rule, the burden is on the Member to receive pre-approval in writing from INDYCAR. If not, the Member assumes the risk of noncompliance. Failure to gain an advantage by a Rule violation may not reduce or negate a penalty.

B. INDYCAR Authority –

(1) The Rules shall be applied, construed and interpreted by Officials, and the Official's application, construction and interpretation shall be final and binding.

(2) INDYCAR reserves the right to revise the Rules at any time, including without limitation during an Event. Notices, bulletins, supplementary rules, regulations and penalties are effective on the date and time issued, regardless of the date and time when a Member receives actual notice.

(3) Officials shall have the right to authorize and supervise Events of any kind; to make and construe Rules and to render decisions concerning them; to grant, approve, refuse or withdraw Licenses, memberships, and sanctions; to assign and cancel dates for Events; to appoint and rescind the appointment of Officials; to impose and remove penalties for any violation of the Rules; to establish standards of eligibility for participation in Events; to establish Rules for its own procedure; and to do any and all things which, in its judgment, are consistent with the enhancement of the Events. Any and all actions and decisions which Officials are authorized and empowered to take under the Rules may be taken, or not taken, by Officials in their discretion.

(4) Officials also reserve the right to take whatever action and/or impose whatever penalty it deems necessary to maintain the integrity of INDYCAR, Firestone Indy Lights and/or its Events.

C. Officiating –

(1) INDYCAR will select Officials as it deems appropriate.

(2) Officials shall have the discretion and authority to take any and all actions and make any and all determinations they deem necessary or appropriate during, or in connection with, an Event, including without limitation determinations as to whether a Rule violation has occurred and whether a penalty should be imposed.

(3) INDYCAR in its discretion shall have the right to determine whether or not to publish or cause to be published a notice stating that INDYCAR has penalized any Member and/or rendered a judgment on a protest or appeal. If published, the notice may include without limitation a description of the penalty or judgment and names of the affected Members. Having accepted the privileges and obligations of membership, the Members referenced in any such notice waive any and all rights of action against INDYCAR and/or against any individual publishing such notice. Officials may publicize the results referenced in such notice in the posting and awards or otherwise.

(4) Officials will secure necessary timing and scoring and technical equipment and record all timing and scoring and technical information, including the standings of an Event; control the designated timing and scoring and technical areas; provide competition information to the Competitors, the Event Promoter, and the press; and facilitate the award distributions. Officials shall be the final authority on the content of the official posting of all Entry lists, practice sessions, qualifications results, Race finishes, point standings and award distributions.

(5) Officials may order the completion, postponement or cancellation of an Event or any portion thereof in the case of inclement weather, physical condition of the Track, or for any other reason. Officials may terminate a Race before its

scheduled number of laps or allotted time and in such case determine the Race results and disposition of the awards, and may terminate a Race after one or more Cars have finished. Officials may reduce the scheduled number of laps, allotted time, or they may declare an Event completed, postponed or abandoned.

(6) As soon as practical after the conclusion of an Event, Officials shall prepare a report giving the results of the Event and may identify protests lodged and any discipline administered. INDYCAR shall keep a record of Cars declared out of the Race and the reason therefor.

D. Acceptance of the Rules –

(1) Every Member who is involved in and/or participates in any way in any Event shall be deemed to have a full awareness and understanding of, and to accept, the Rules.

(2) Every Member agrees to follow the direction of Officials with respect to the enforcement of these Rules or be subjected to penalties for failure to comply with such directions.

E. Assumption of Risk, Liability Release, Acknowledgment and Indemnity –

(1) ASSUMPTION OF RISK - EVERY MEMBER AGREES TO BE BOUND BY THE RULES AND ASSUMES ALL OF THE RISK OF SUCH MEMBER'S INVOLVEMENT AND/OR PARTICIPATION IN AN EVENT.

(2) LIABILITY RELEASE - RECOGNIZING THAT AUTOMOBILE RACING CAN BE A HAZARDOUS UNDERTAKING, MEMBERS, FOR THEMSELVES, THEIR HEIRS,

EXECUTORS, REPRESENTATIVES, SUCCESSORS AND ASSIGNS, AGREE, BY THEIR MEMBERSHIP, THAT THEY RELEASE AND DISCHARGE INDYCAR, THE OFFICERS, DIRECTORS, EMPLOYEES, AGENTS, AFFILIATES, REPRESENTATIVES, OWNERS, SUCCESSORS AND ASSIGNS OF INDYCAR, AND OTHER MEMBERS, FROM ANY AND ALL LIABILITY FOR DAMAGES TO PROPERTY, PERSONAL INJURY, AND/OR DEATH, IN ANY WAY RELATING TO ANY EVENT OR THE MEMBERS' INVOLVEMENT AND/OR PARTICIPATION IN THE EVENT, REGARDLESS OF HOW THE CLAIM MIGHT ARISE INCLUDING WITHOUT LIMITATION RACE OFFICIATING, RULE INTERPRETATION AND VIOLATIONS, PHYSICAL CONDITION OF THE TRACK, AND/OR EMERGENCY TREATMENT OR RESCUE.

(3) ACKNOWLEDGMENT –

(a) MEMBERS RECOGNIZE THIS RELEASE APPLIES EVEN IF THE RELEASED PARTIES OR ANY OF THEM ACTED NEGLIGENTLY AND UNDERSTAND THAT MEMBERS MAY BE ASKED TO ACKNOWLEDGE THIS ASSUMPTION OF RISK AND RELEASE BY OTHER AGREEMENTS THEY MIGHT SIGN AS A PREREQUISITE TO PARTICIPATE IN AN EVENT OR EVENTS.

(b) EACH MEMBER ACKNOWLEDGES THAT THE MEMBER HAS MADE THE MEMBER'S SPOUSE AND/OR DEPENDENTS AWARE OF THE MEMBER'S DECISION TO ASSUME AND

INCUR THE RISK ASSOCIATED WITH RACING WITHOUT THE RIGHT TO PURSUE CLAIMS OF WRONGDOING.

(4) INDEMNITY – EACH MEMBER ACKNOWLEDGES THAT MEMBER IS RESPONSIBLE FOR VIOLATION OF MEMBER'S AGREEMENTS BY MEMBER, MEMBER'S REPRESENTATIVES INCLUDING LOVED ONES AFFECTED BY MEMBER'S PARTICIPATION, AND MEMBER'S PARTICIPANTS AND GUESTS. THIS RESPONSIBILITY APPLIES TO ALL VIOLATIONS OF MEMBER'S AGREEMENTS WITH INDYCAR. THIS INCLUDES THE MISUSE OF CREDENTIALS AND THE FAILURE TO ACCEPT THE ASSUMPTION OF RISK, THE WAIVER AND RELEASE OF LIABILITY, THE BINDING NATURE OF THE RULES, INDYCAR'S INTREPRETION OF THE RULES, AND THE FINALITY OF THE APPEAL PROCEDURE. MEMBER UNDERSTANDS THAT THIS RESPONSIBILITY INCLUDES THE DUTY TO INDEMNIFY AND HOLD INDYCAR HARMLESS FROM THE CONSEQUENCES AND DAMAGES ARISING FROM THE VIOLATION.

1.2 Safety -

A. Safety Policy - While INDYCAR seeks to maintain safe conditions for Competitors taking into account all aspects of the Event, Members recognize that conditions may not be safe, and can be affected by human error. All Members acknowledge and agree that racing is a hazardous activity and their participation is with expressed assumption of this risk.

B. Safety -

(1) While acknowledging the inherent risk of racing to Competitors and other Members participating in an Event, Members are personally responsible for the safety of their racing equipment and their own safety. No Event Promoter, INDYCAR or any Manufacturer is responsible for the adequacy of a Member's racing equipment or racing activity to accomplish this purpose. No Event Promoter, INDYCAR or any Manufacturer makes any representation, warranty or covenant that safety equipment and/or personnel will prevent or reduce the Member's risk or extent of injury in an Event.

(2) Officials may take any action, including canceling, postponing, temporarily stopping or delaying an Event, if Officials determine in their discretion that safety requires such action. Officials may order off the Track any Member or Car that Officials determine constitutes a hazard. Officials may prohibit any Member or Member's equipment from entering or continuing in an Event if Officials consider the Member or Member's equipment to be reckless, hazardous or acting without due consideration to others. None of such decisions during an Event may be protested or appealed. In the event a Driver is ordered off the Track due solely to driving, the Entrant may replace the Driver with a qualified Driver approved by Officials and continue in the Event.

C. Security -

(1) Only authorized personnel are permitted on the Track and other locations designated by INDYCAR or an Event Promoter including without limitation spotter stands, corner worker stations, safety truck locations, photographer locations and broadcast platforms,

(2) INDYCAR and the Event Promoter have the right

to engage in such searches of individuals and property at any Event facility as they deem necessary or appropriate for security of the Event. If they deem necessary, INDYCAR and the Event Promoter have the right to remove any individual and/or property from the Event facility.

(3) INDYCAR may penalize any Entrant, Associate or other Member whose representative or equipment enters a restricted area at an Event facility prior to the scheduled opening time or remains in a restricted area at an Event facility after the scheduled closing time without prior approval from INDYCAR and the Event Promoter.

(4) Only Members possessing a valid driver's license may operate a motorized vehicle in a restricted area during an Event. Only INDYCAR-approved vehicles are permitted in the pit area. INDYCAR and/or an Event Promoter may have additional or different requirements for a particular Event, and INDYCAR may modify the foregoing Rule accordingly.

(5) Members must not operate or permit another individual to operate a motorized or non-motorized vehicle at the Event facility recklessly or without due consideration to Members, spectators or others.

(6) Smoking is not permitted on the Track, in the pit area, or in any fuel service area. INDYCAR and/or an Event Promoter may have additional or different requirements for a particular Event, and INDYCAR may modify the foregoing Rule accordingly.

D. Medical/Rescue Requirements and Injury Reports –

(1) Officials may require the Event Promoter to use, in compliance with local regulations and/or ASN requirements, medical/rescue personnel and equipment acceptable to INDYCAR to provide

Members with assessment and treatment of emergency medical conditions including breathing difficulty, spinal injury, cardiopulmonary arrest, and external bleeding.

(2) A Driver may be required to demonstrate ability to exit the Car to Officials' satisfaction.

(3) A Driver involved in a crash or injured in another incident during an Event must report as directed by Officials and may not continue in the Event nor participate in future Events without clearance from Officials.

(4) Any other Member involved in a crash or injured in another incident during an Event must report to the medical center or as directed by Officials before departing the Event facility prior to the conclusion of an Event.

E. Biomedical Research and Device Test Policy – All Members must comply with INDYCAR's Biomedical Research and Device Testing Policy available from the INDYCAR office.

F. Data Sharing Policy - All Members agree:

(1) INDYCAR owns all data collected by or on behalf of INDYCAR including without limitation all data from broadcast telemetry, in-car cameras, impact recorders and ear pieces.

(2) INDYCAR may disclose the data to third parties for any reasonable purpose including without limitation safety and/or medical research.

(3) If an individual desires to receive any such data from INDYCAR, the individual shall submit such request in writing to the Senior Official.

(a) The written request shall specify the data requested and the proposed use of the data.

(b) The decision whether to provide the data shall be in the discretion of INDYCAR taking into account such factors as the nature of the data requested, the uses for which the individual requests the data and whether or not consent and/or approval of any other individual is required or appropriate in order to release the data.

(c) The individual will be required to execute an agreement regarding approved uses for the data and the confidential treatment of any data that INDYCAR approves for use by the individual.

(4) Notwithstanding the foregoing, an Entrant may record its own pit stop activities from its own pit area during Events for use only by such Entrant for internal evaluation of its own pit stop procedures. All other activities and/or uses require prior INDYCAR written approval.

G. Safety Inspections - Officials may inspect all equipment prior to each Event and re-inspect equipment at any time. An Entrant may be required to replace seats, seatbelts, helmets, headrests, head restraint systems, and other equipment at any time.

H. Personal Safety Equipment -

1. Drivers

a. All Drivers must wear:

- i.** Fire resistant one piece uniform conforming to SFI 3.2A/5 specification;
- ii.** Fire resistant socks;
- iii.** Fire resistant shoes;

- iv. Fire resistant gloves;
- v. Nomex long sleeve underwear; and
- vi. Fire resistant head sock.

b. All removable dental appliances, chewing gum, rings, watches and other jewelry and comparable items must be removed before a Driver participates in an on Track Event.

c. **Helmets**

- i. All Drivers must wear safety helmets designed specifically for automobile racing that meet or exceed the 2005 Snell Foundation specifications SA or SFI 31.1 certifications and are labeled as such. Helmets must be spherical in shape and be fitted with a face shield that has an INDYCAR-approved positive latching mechanism designed to keep the shield down in the event of a crash. Aerodynamic devices must not protrude more than 0.250 inches from the surface. Flat back designs are not permitted. All helmets must be fitted with the approved helmet removal system.
- ii. All helmets must be inspected and approved by Officials before use and are

subject to confiscation and re-inspection by Officials at any time. Officials shall affix stickers to the helmets signifying approval for use. At any time, Officials may remove the approval stickers and require the helmets to be re-inspected and refurbished by an SFI certified helmet manufacturer before INDYCAR will consider them for re-approval. The helmet manufacturer must submit to INDYCAR documentation stating the refurbished helmet is approved by SFI for use in competition.

d. Head Restraint Systems

- i.** INDYCAR requires the use of head restraint systems. Head restraint systems must meet or exceed SFI 38.1 certifications and be approved by INDYCAR.
- ii.** Officials shall issue a serial number to each head restraint system. At any time, Officials may require the head restraint system to be re-inspected and refurbished by the SFI certified head restraint system manufacturer before INDYCAR will consider them for re-approval. The

head restraint system manufacturer must submit to INDYCAR documentation stating that the head restraint system is approved by SFI for use in competition.

- e. **Ear Pieces** – All Drivers must wear INDYCAR-supplied instrumented ear pieces. Ear pieces must be presented to Officials for testing before each Event and upon request. Repair and/or replacement of the ear pieces shall be the Driver's expense.

2. Crew Members, Other Competitors and Officials –

a. All Competitors and Officials in the pit area must adhere to the following dress code:

- (i) Long pants;
- (ii) Closed-toe shoes; and
- (iii) Shirts with sleeves (no tank tops).

b. This Rule does not apply to individuals in the pit area who are not Competitors or Officials or to any individuals in the garage area or non-restricted areas. INDYCAR and/or an Event Promoter may have additional or different requirements for a particular Event.

1.3 Emblem Display on Uniforms, Cars and Other Equipment – All Members agree to comply with the 2011 INDYCAR Style Guide available from INDYCAR at the INDYCAR offices.

1.4 Advertising –

A. INDYCAR in its discretion may regulate the

advertising of any product on equipment, apparel or otherwise in connection with a Member, INDYCAR, Firestone Indy Lights or an Event.

B. Advertising may not be displayed until it has been approved by INDYCAR. INDYCAR in its discretion may disapprove advertising for any reason including but not limited to advertising which it determines is offensive, inappropriate, illegal, undignified, in conflict with any INDYCAR or Event Promoter sponsorship, potentially confusing or may detract from the interest in an Event and/or the integrity of INDYCAR and/or Firestone Indy Lights.

C. INDYCAR may require a Member to agree in writing with a policy statement regarding advertising of a product.

D. Product advertising must comply with all Rules including without limitation size.

1.5 Product Use -

A. A Member shall not make a false public statement concerning any product used or said to have been used in an Event. An Entrant may be required to provide INDYCAR with an affidavit certifying product use. Display of an emblem on a Car or uniform does not constitute a statement concerning use.

B. INDYCAR in its discretion may certify that a product was used at Events. A product manufacturer desiring to have INDYCAR certify that its product was used in an Event must follow the procedures outlined in this Rule 1.5.

C. To be eligible to receive certification of product use, the product manufacturer must agree in writing to the following:

(1) The product manufacturer must agree to be bound by the Rules and must agree to be subject to penalty pursuant to the Rules.

(2) Any product to be advertised as being used in an Event must be reported to INDYCAR in writing at least 30 days prior to the Event and approved for use by INDYCAR. The product advertised must be used during the Event, and its use must be checked and certified by INDYCAR.

(3) Product manufacturers posting awards contingent on product use and the display of advertising during an Event must provide Officials with a statement of the conditions at least 30 days prior to the Event. The product manufacturer shall provide Officials with proof of award distribution in accordance with these conditions within 30 days of certification by INDYCAR of the product use.

(4) Any advertisement of products and the related use of these products during an Event must be consistent with the facts as determined by INDYCAR and must not be likely to deceive or mislead the general public.

(5) INDYCAR may add requirements as it deems appropriate in its discretion.

1.6 Event Personnel and Operations -

A. General

(1) An Entrant is not permitted to utilize a signboard without INDYCAR approval.

(2) At all Oval Events, spotters are required. They must be in the designated location(s) and have a yellow condition pager and a radio capable of communicating with the Driver and an individual in the Entrant's pit.

(3) An Entrant is not guaranteed a practice session or a minimum amount of green condition time during a

practice session. Practice sessions may include all Cars or be divided into groups.

B. Meetings and Activities –

(1) INDYCAR may schedule mandatory meetings and/or activities for Members. The Race Director may require a meeting with Member(s) at any time. Each Member must attend all official meetings and other activities designated by INDYCAR as mandatory for that Member at the times and locations designated by INDYCAR. These may include the following:

(a) Driver Meetings –

(i) INDYCAR may conduct one or more meetings of Drivers to discuss general application, construction and interpretation of the Rules and any specific Rules applying to a particular Event.

(ii) Attendance at such meetings is limited to the Driver participating in the Event and any two of the following representatives for Entrant: owner, team manager, chief mechanic, spotter.

(b) Team Manager Meetings - INDYCAR may conduct one or more meetings of team managers to discuss general application, construction and interpretation of the operational or logistical Rules and any specific Rules applying to a particular Event.

(c) Chief Mechanic Meetings - INDYCAR may conduct one or more meetings of chief mechanics to discuss general application, construction and interpretation of the technical Rules and any specific Rules applying to a particular Event.

(d) Driver Autograph Sessions – INDYCAR may conduct one or more autograph sessions of Drivers during each Open Test and Race weekend.

(e) Driver Introductions – INDYCAR may conduct one or more Driver introductions during each Race weekend.

(f) At-Track: Driver agrees media and marketing activities during an Event are essential to a successful Event including without limitation:

- (i) Practice: Fastest of the Day post-practice media center appearance
- (ii) Qualifications: Pole qualifying media “bullpen” appearance; Pole winner photograph obligations; Immediately following qualifications, media center appearance; the pole winner and outside front row starter
- (iii) Pre-Race: In preparation for a Race, Drivers shall follow the instructions of Officials. Unless otherwise directed, the Drivers shall proceed to the Pre-Race stage and fully participate in pre-Race ceremonies including without limitation any Driver introductions and/or Track laps.
- (iv) Post-Race: Upon completion of a Race, all Competitors shall follow the instructions of Officials. Unless otherwise directed, the top three finishers in the Race shall proceed to victory lane as instructed and fully participate in post-Race ceremonies including not removing, obscuring or otherwise altering any sponsor recognition. Specifically at a minimum, this includes the following:
 - a. The winning Driver must attend and participate in post-Race interviews in victory lane. The winning Driver and Car owner (if the owner is in attendance) of a Race agree to permit

the display on the Car in victory lane, as designated by INDYCAR, one item from the series title sponsor and one item from the Car's sponsor as determined by INDYCAR in its sole discretion, including size, location and placement of such item(s). The winning Entrant agrees to participate in a photograph with the Event sponsor(s) and their guests.

- b. Unless otherwise directed, the 2nd and 3rd place Drivers must stop in pit lane or such other area as designated by INDYCAR and participate in media interviews.
- c. The 4th and 5th place Drivers must stop on pit lane or such other area as designated by INDYCAR and participate in media interviews.
- d. The 2nd and 3rd place Drivers must proceed to victory lane and join the Race winner in post-Race ceremonies. The top three finishers must wear INDYCAR provided hats in the following order: Tire manufacturer and Firestone Indy Lights.
- e. Immediately following victory lane ceremonies, the Race winner, 2nd place Driver and 3rd place Driver must attend and participate in post-Race interviews in the media center.
- f. All other Drivers agree to attend and participate in the post-Race media center interview process, if requested.
- g. All selected Cars must be presented to Officials at technical inspection within one hour of the conclusion of the Race.

(h) Championship: All Drivers and Entrants mathematically eligible to win the Driver and/or Entrant end of season point standings agree to attend and participate in activities as follows:

- (i) End of season Event venue for final Race: a media activity at the approximately four weeks prior to the end of season Event
- (ii) During the final five (5) Races in the Racing Season: designated pre-Race and/or post-Race media requirements, including national media teleconferences, satellite media tours and/or radio tours as directed by INDYCAR
- (iii) End of Season Event Week: a media event as designated by INDYCAR
- (iv) Firestone Indy Lights Champion: a national media tour that could include a trip(s) to national media markets, if requested.

(i) Celebration: The winning Driver and Car owner must attend and participate in the Celebration at such times and locations as designated by INDYCAR.

(2) Penalties – The Race Director in his discretion shall determine whether a Member has failed to attend or engaged in inappropriate conduct during a meeting or mandatory activity.

(a) First Offense - \$500 and/or require attendance at an additional/substitute meeting or activity.

(b) Each Additional Offense – INDYCAR may double the fine, require attendance at an additional/substitute meeting or activity, and/or INDYCAR may require the Driver's Car to start the Race at the rear of the starting field (in the case of a Drivers Meeting).

Whether in attendance or not, Members shall be charged with knowledge of the matters

discussed at meetings (whether mandatory or not). A Member and the Member's Entrant waive the right to protest and/or appeal any penalties that may be assessed for any violation of the Rules if the Member was not present at the meeting when the subject was discussed.

(3) No cellular telephones, wireless mobile devices, personal digital assistants or other recording devices may be used during any mandatory meeting and/or activity.

II. MEMBERSHIP

2.1 General - INDYCAR is a membership organization. Each Member shall be deemed to be an independent contractor of INDYCAR, and the relationship between INDYCAR and a Member shall not be deemed to be a partnership, joint venture or employment relationship by virtue of the membership.

2.2 Application

A. Each applicant may be required to submit the following properly executed materials for INDYCAR approval in the form required by INDYCAR:

(a) Membership application on a form provided by INDYCAR,

(b) Membership application fee (if any),

(c) Substance Abuse Policy Authorization for Screening and/or Testing and Release (if the applicant is a Competitor or Official),

(d) Participant Authorization for Use and Disclosure of Protected Health Information, and

(e) Any other materials required by INDYCAR.

B. Qualifications for membership shall be determined by INDYCAR and may be periodically revised.

C. Each applicant agrees to fulfill all contractual obligations such applicant and/or applicant's affiliates may have to INDYCAR, Event Promoters, Manufacturers and their affiliates. Each applicant agrees that INDYCAR, Manufacturers and their affiliates shall have the remedy of

specific performance with respect to any and all such obligations in addition to all other rights and remedies available at law or in equity and notwithstanding any terms to the contrary in any other agreement.

D. Each applicant must pay any and all outstanding financial obligations owed by applicant or its affiliates to INDYCAR, Manufacturers and their affiliates or make other arrangements acceptable to INDYCAR, Manufacturers and their affiliates.

E. Acceptance or rejection of any membership application is in the discretion of INDYCAR, although the rejection of a membership application may be protested and/or appealed in accordance with the procedures set forth in Rule XII and Rule XIII.

F. If an individual/entity participates in an Event without having properly submitted a fully-executed membership application, the individual/entity, by such participation, nevertheless agrees that the individual/entity is subject to all Rules and all statements, releases and obligations appearing in the membership application as if the individual/entity had properly submitted a fully-executed membership application.

G. Regardless of where the application is executed by the applicant and/or accepted by INDYCAR and/or the credential issued, applicant recognizes and agrees that the Member's application and associated agreement is an Indiana contract and forms a contractual relationship established in the State of Indiana and governed by the laws of Indiana. This contract and relationship is a legal one and applicant should consult his/her attorney if he/she has any legal questions.

2.3 Term - Unless otherwise noted, a membership expires on December 31 of the calendar year. INDYCAR may issue a credential which may only be valid for a designated period of time or designated Event(s) as INDYCAR deems appropriate.

2.4 Interim Review of Qualifications - INDYCAR in its discretion may review the qualifications of a Member at any time after accepting a membership to determine whether the Member shall continue to qualify for a membership under these Rules.

2.5 Acknowledgement of Release and Assumption of Risk - INDYCAR may periodically request a Member to acknowledge the release and assumption of risk in the membership application, but the failure of INDYCAR to request and/or a Member to sign an acknowledgement does not negate the release and assumption of risk in the membership application or in these Rules.

2.6 Applicable Laws and Jurisdiction -

A. To avoid the need for specific inquiries, each Member represents, warrants and covenants to INDYCAR and its affiliates that such Member has complied with and at all times will comply with all applicable local, state, federal and country laws, rules and regulations including but not limited to income/sales/use tax, safety/health, transportation, workers compensation, and frequency communications.

B. If there is a misrepresentation and/or a breach of this warranty and covenant, such Member shall indemnify and hold INDYCAR and its affiliates harmless from any loss or expense incurred by INDYCAR or its affiliates as a result of any noncompliance including without limitation claims of INDYCAR's or its affiliates' sole or contributory negligence and/or a claim that INDYCAR or its affiliates failed to supervise or achieve compliance.

C. These Rules shall be governed by and construed in accordance with the laws of the State of Indiana, including its choice of law provisions, and the Members submit to exclusive jurisdiction in Indianapolis, Indiana for any administrative or judicial proceedings.

D. If any litigation involving a Member and INDYCAR is not dismissed pursuant to Rule 13.9, the Member agrees that the matter will be tried only before a judge of competent jurisdiction in Marion County, Indiana, and the Member hereby waives any right to trial by jury in such action.

2.7 Conduct Identification – A claim of intentional or willful and wanton conduct by one Member against another should never be made unless the claim can be supported by established facts. Even if factually supportable, such a claim can not continue unless the notice required in the membership application is timely completed.

2.8 Litigation – Each Member agrees to reimburse INDYCAR, its affiliates, and other named Members (“INDYCAR Group”) for all costs of litigation including without limitation travel expenses and attorneys’ fees if either of the following conditions occurs:

A. The Member initiates or otherwise causes a member of the INDYCAR Group to be named as a party in a legal proceeding not permitted or contemplated by the Rules; or

B. The Member requests or compels a member(s) of the INDYCAR Group’s participation in a manner other than as a party to the lawsuit.

2.9 Categories – The following membership categories exist:

Entrant

Driver

Associate

Official

Sponsor

Event Promoter

Media

VIP

2.10 Age –

A. Before an individual shall be eligible for a membership or License and/or to participate in an Event, such individual must be at least 18 years of age and of sufficient age to participate in an Event and to sign an enforceable contract and/or a separate waiver and release form approved by INDYCAR.

B. INDYCAR may have additional or different eligibility requirements for a particular Event. INDYCAR in its discretion reserves the right to limit participation to an age greater than 18 or to require additional documentation as a prerequisite to participation.

C. No one under age 18 shall be permitted in pit lane during Events unless permitted by applicable insurance requirements and previously approved by INDYCAR and the Event Promoter.

D. At INDYCAR's discretion, an individual, age 17, may be allowed to apply for a Driver's License. All agreements and documentation as to additional obligations as required by INDYCAR must be completed to INDYCAR's satisfaction before the application will be considered. If accepted and for the duration of time that INDYCAR allows, the individual will have all rights of a licensed driver.

2.11 Moral Fitness –

A. The past or current conduct of an applicant or Member can have adverse consequences to INDYCAR.

B. An applicant or Member must honestly answer questions raised by INDYCAR as to moral character.

C. Applicants and Members agree INDYCAR in its discretion may refuse a membership application or revoke a membership for any reason including but not limited to those related to personal conduct, decency and whether or not any conduct of the applicant or Member creates adverse notoriety with respect to INDYCAR, Firestone Indy Lights or an Event.

2.12 Physical and Psychological Fitness –

A. INDYCAR may require any applicant or Member to complete a medical history form and/or complete and pass a medical examination as directed by Officials to determine physical and psychological fitness to receive a membership or License and/or to participate or continue in an Event. At any time, the Officials may require a Member to be examined by a designated medical professional at the Member's cost.

B. In addition to Competitors and Officials, any Member who is required to complete a medical history form and/or complete and pass a medical examination shall also be required to immediately notify INDYCAR medical professionals at any time if such Member takes, or is prescribed to take, any drugs or medication (whether or not prescription drugs or medication) and/or if such Member is diagnosed with any medical condition (including pregnancy) by any medical professional or such Member otherwise knows or suspects that the Member has a medical condition that may impair his/her ability to participate in an Event.

C. Each applicant and Member waives any and all claims regarding any medical examinations and/or examination results, and/or the use or disclosure of such examinations and/or examination results by INDYCAR, its agents and/or its medical professionals including without

limitation claims of invasion of privacy and/or breach of confidentiality, notwithstanding whether such claims arise from strict liability, sole or contributory negligence of INDYCAR, breach of contract, or any other legal theory.

2.13 Medical Examinations and Treatment –

A. Examinations and/or treatment of Members, including emergency rescue, performed by medical professionals acting on behalf of INDYCAR are based upon a relationship established in the State of Indiana.

B. Members acknowledge that the medical professionals are acting pursuant to their contractual obligations with INDYCAR and are not acting or rendering personal medical services to the Members. Members acknowledge that they shall have their own personal physicians.

2.14 Fitness to Participate - Members acknowledge that while the INDYCAR medical professionals render an opinion as to fitness, the final determination of a Member's ability to participate is made by the Senior Official.

2.15 Substance Abuse – Members must not use or be under the influence of stimulants, depressants or tranquilizers including but not limited to alcoholic beverages and narcotics during an Event. All Competitors and Officials must complete and return to INDYCAR the current Substance Abuse Policy Authorization for Screening and/or Testing and Release. Every Competitor and Official, at all times, shall comply with the provisions of the Substance Abuse Policy.

2.16 Alcoholic Beverages, Illegal Substances, and Unauthorized Weapons - The use or possession of alcoholic beverages, illegal substances, or unauthorized weapons of any sort by a Member during an Event, as well as the presence of alcoholic beverages, illegal substances, and unauthorized weapons on the Track, or in other restricted areas during the Event, is strictly prohibited. Any Member violating this Rule may be disqualified and/or suspended and may be subject to additional penalties. Any Member who shows visible signs of

exhaustion, physical or psychological impairment, or other physical or psychological irregularities may be disqualified and/or excluded from an Event and subjected to additional examinations and/or penalties.

2.17 Substance Abuse Policy –

A. Any Member may be required to undergo a physical or psychological screening, test or other examination which may include without limitation the collection of urine, blood, oral fluid/saliva, hair breath and/or any other scientifically-acceptable method of analysis in order to be involved in and/or participate or continue in an Event, and such Member waives any and all claims of invasion of privacy and/or breach of confidentiality as set forth in Rule 2.12.

B. INDYCAR reserves the right to conduct targeted screening and/or testing and scheduled and/or random screening and/or testing for drugs and other substances at its discretion, and the Member agrees to submit to such screening and/or testing if requested. Screening and testing may be for any drug, medication or other substance including without limitation alcohol. INDYCAR may suspend or otherwise penalize any Member for failure to promptly cooperate with any such request for screening and/or testing. INDYCAR may also suspend or otherwise penalize any Member if the results of any screen or test are positive for any illegal substance or any substance that in the opinion of INDYCAR would enhance, impair or otherwise affect the Member's ability to be involved in and/or participate in an Event.

2.18 Violation of Laws – Being charged with a violation of the law, whether alcohol/substance abuse or any other laws, may be grounds for suspension or other penalty. Any Member charged with any violation of the law relating to alcoholic beverages or illegal substances, or charged with any felony, must notify the Race Director prior to the next scheduled Event or within 72 hours of being so charged, whichever is earlier.

2.19 Medical Records - Each Member agrees and consents that in the event of injury or death arising in any way out of the Member's involvement and/or participation in an Event, INDYCAR may obtain access to and copies of any and all medical records of the Member related to such injury or death.

2.20 Memberships, Licenses and Credentials –

A. Prior to gaining access to restricted areas, each individual must have the necessary and appropriate credential. The holder of a membership, License or other credential shall produce it for inspection upon demand of any Official or security personnel at any Event along with any other document needed to confirm identification.

B. The annual credential consists of both the lanyard and the hard card. Use of one without the other invalidates the annual credential. In addition, a Member must not use a prior Event's, prior season's or other series' credential.

C. A membership, License or any other credential (including race mode) may not be disassembled, transferred, assigned, sold, altered or duplicated. It must be used only by the Member to whom it is issued. If a Member intentionally or unintentionally disassembles, transfers, assigns, sells, alters, duplicates or otherwise permits another individual or entity to use or attempt to use the membership, License or credential, then the Member may be penalized and shall indemnify and hold INDYCAR harmless from any loss or expense incurred by INDYCAR arising in any way from Member's action, even if Member asserts that INDYCAR's loss or expense is due to INDYCAR's negligence.

D. The Rules regarding memberships, Licenses and credentials are equally applicable to parking passes, Event credentials, golf cart passes and all other privileges issued to a Member by INDYCAR or an Event Promoter not expressly transferable, assignable or eligible for sale.

E. INDYCAR may require an applicant and/or Member to provide a valid official government-issued identification including photograph and date of birth in order to receive or retain a credential. Acceptable identification includes but is not limited to state driver's licenses, passports, military cards, etc., but does not include identifications issued by educational institutions.

F. Members agree to be responsible for the conduct of their Participants and guests.

III. SANCTIONS/GOVERNING

3.1 Promotion of Events - INDYCAR will sanction/govern Race Events with an Event Promoter through an Event Agreement. The Event Agreement contains additional terms regarding the Race Event, such as those relating to postponement dates.

3.2 Event Promoter Responsibilities –

A. Event Promoters shall be responsible for designated operations of the Events including without limitation responsibility for obtaining and providing, at the Event Promoter's expense, insurance as required by the Event Agreement, safety precautions, services and vehicles for Competitors and spectators including medical/rescue personnel, equipment and facilities (such as ambulances, helicopters and examination facilities and equipment); physical condition of the Track; spectator control; and fire protection, all to meet or exceed the minimum requirements provided by INDYCAR and the ASN.

B. INDYCAR shall not be responsible or in any manner liable for any of the Event Promoter's responsibilities under the Event Agreement or the Rules even though the Event Promoter fails or refuses to perform such functions, duties and responsibilities, in whole or in part, or if INDYCAR voluntarily assumes performance of any or all of the Event Promoter's specific functions, duties and responsibilities.

3.3 Restrictions – Event Promoter shall not schedule any ancillary or supporting entertainment, events or activities that include racing activity on the Track during the Event without prior written approval by INDYCAR, in each instance.

IV.
ENTRANT/DRIVER LICENSING AND
FREQUENCY/CAR REGISTRATION

4.1 General –

A. Licensing criteria are available from the INDYCAR office and may vary depending on the particular on Track activity. Entrants and Drivers must remain in good standing to participate in an Event. All Licenses shall be made on provided forms and submitted for approval. INDYCAR and ACCUS-FIA (and another ASN, if applicable) in their discretion shall determine whether to approve and issue a License application. Applicant shall pay any and all costs associated with satisfying the License criteria. Driver Licenses are not transferable at any time; Entrant Licenses are not transferable without prior written approval.

B. Licenses are revocable at any time and for any reason. Without limiting the foregoing, Licenses for rookie drivers are granted on a temporary basis.

C. Licenses may be limited to a particular type of Events or for a specified period of time.

D. Licensed Entrants and Drivers are eligible to earn awards and points as described in the Rules.

E. Eligibility for a License shall be determined based on such factors as are indicative of the applicant's ability to participate satisfactorily in an Event.

F. Fees may be charged for Licenses.

(1) Fees are non-refundable. No fee or part thereof shall be refunded to a licensee because the licensee ceases to participate in Events regardless of the

reason for such cessation.

(2) License fees are for an entire season and will not be pro-rated for any reason including without limitation for Members who begin participating after the first Event.

G. A License is valid only for the current season and/or as otherwise restricted. Unless otherwise noted, all Licenses shall expire on December 31 of the calendar year.

H. An applicant may protest or appeal denial of a Driver or Entrant License and membership application, grade of Driver's License, determination of rookie status or eligibility for a rookie orientation or refresher test in accordance with the procedures set forth in Rules XII and XIII.

I. INDYCAR may continuously re-evaluate the eligibility and performance of a Driver or Entrant to determine if the Driver or Entrant shall remain licensed. As part of such evaluation, INDYCAR may consider input from Officials, Drivers, and others as INDYCAR determines appropriate and may require a Driver or Entrant to participate in Testing under the observation of Officials, Drivers and others.

4.2 Entrant and Driver Licensing -

A. Entrant License -

(1) General –

(a) The individual signing the application represents that the individual is authorized to act on behalf of the named Entrant in all matters. Additional corporate representatives may be listed, and the authority of any individual may be limited. One corporate representative must be present at Open Test and Race Events.

(b) If a corporate representative's status changes, an individual authorized to act on behalf of the Entrant may be required to submit a new application for that Entrant for approval. An Entrant may be required to submit another Entrant License fee and resubmit any other materials including but not limited to Engine Lease Agreements, Entry forms, etc.

(c) Upon request, INDYCAR must be provided information satisfactory to INDYCAR regarding ownership of an Entrant.

(2) Eligibility -

(a) General - After receipt of the application, the Entrant's competitive viability will be assessed to determine whether to approve and issue the License. Factors taken into account may include:

(i) purchase and/or lease agreements with Manufacturers;

(ii) service agreement with the Engine builder (if any);

(iii) purchase and/or lease agreement for its shop; and

(iv) existence of employment agreements with key personnel including but not limited to manager, engineer, chief mechanic and Driver.

(b) Entry - Upon issuance of the Entrant License, the Entrant may submit Entry forms identified by the Car number assigned to that Entrant License. The Entry (Car with Driver) must display the Car number at all times during

the Event, and all points and awards earned by this Entry will be credited to that Car number unless otherwise determined by INDYCAR. An Entrant intending to compete with multiple Entries at a single Event must obtain an Entrant License with a unique Car number for each Entry or satisfy such other requirements as INDYCAR may prescribe.

(c) Chief Mechanic –

(i) Each Entry must have a chief mechanic.

(ii) The chief mechanic is responsible for the Car complying with the Rules.

(iii) The chief mechanic must be present in his/her Car's assigned pit when the Car is on the Track and must accompany the Car during all technical inspection processes.

(iv) Entrant agrees its chief mechanic shall serve as an authorized corporate representative regarding all issues related to technical inspection.

(v) An Entrant shall replace its chief mechanic if INDYCAR in its discretion determines that the chief mechanic is not sufficiently qualified.

(d) Manufacturers – The Manufacturers may require an Entrant to enter into lease and/or purchase agreements in a form acceptable to the Manufacturers and meet other Manufacturer requirements before the Manufacturers are obligated to supply components to such Entrant.

B. Driver License -

(1) General –

(a) Licenses may be approved and issued to individuals determined eligible by INDYCAR in its discretion to compete in an Event and who otherwise meet the application requirements.

(b) The determination of whether the applicant may take a driver's Test and whether the applicant successfully completed the Test shall be made by INDYCAR in its discretion.

(c) INDYCAR and/or ACCUS-FIA (and another ASN, if applicable) in their discretion shall determine the grade of the License issued to a Driver.

(d) In order for a driver to compete in any Event, the driver must hold a Driver's License and at any time may be required to:

i) participate in any INDYCAR required Testing,

ii) provide an updated resume, certified birth certificate, and/or

iii) furnish a current medical clearance acceptable to INDYCAR attesting to the driver's fitness for racing.

At any time, INDYCAR may require a foreign Driver to provide proof of United States residency and an international letter of authorization from the Driver's ASN.

(2) Eligibility –

(a) An applicant must have sufficient competitive driving ability and experience as

determined by the Race Director in his discretion.

(b) INDYCAR's determination as to ability will take into account all such factors as INDYCAR deems relevant. The criteria taken into account by INDYCAR are listed below. The criteria are subject to change at any time. An applicant must contact INDYCAR for the current Race-specific criteria.

(c) INDYCAR may require the applicant to provide:

(i) A current resume containing a complete history of the applicant's competition to date and demonstrating the applicant's ability to properly handle the Car;

(ii) A letter of recommendation from the race director of the series in which the driver last competed; and

(iii) Such other information as INDYCAR may request.

(d) Medical Information - The applicant must provide the medical information required by INDYCAR and must successfully complete INDYCAR-prescribed physical and psychological examinations, which may include without limitation eye, neurological and substance abuse screening and/or testing.

(e) Rookie, Rookie Orientation Test and Refresher Test

(i) Rookie - INDYCAR in its discretion shall determine whether a Driver is a rookie. If a Driver begins the season as a

rookie, he/she remains a rookie until the end of the season.

(ii) Rookie Orientation Test – An applicant must demonstrate Car control, and placement and a consistent driving pattern. INDYCAR may require additional Testing including without limitation Testing in close proximity to other Cars, before an applicant may be permitted to participate in an Open Test and/or Race.

(iii) Refresher Tests - An applicant including but not limited to a driver who has not participated as a Driver in an Event during the past 12 months may be required to successfully complete a refresher Test. In lieu of a refresher Test, INDYCAR in its discretion may require an applicant to successfully complete a rookie orientation Test.

(iv) Costs – An applicant shall pay all costs incurred by INDYCAR relating to such Tests.

4.3 Radio and Wireless Frequency Registration - All Members agree INDYCAR owns all voice, data and telemetry collected by or on behalf of INDYCAR including without limitation all voice, data and telemetry from radio and wireless data frequencies.

A. Radio Frequencies – Each Member transmitting or receiving any signal including but not limited to all voice, data and telemetry, but excluding Internet related WiFi (regulated pursuant to Rule 4.3(B)), shall:

(1) Provide the specifications (e.g., manufacturer, make, model, serial number) of the radio to be used in the Car to the INDYCAR-designated

representative prior to the first Race;

(2) Not password-protect or otherwise affect the INDYCAR-designated representative's ability to read the radio to be used in the Car at any time;

(3) Notify the INDYCAR-designated representative immediately upon changing any of the specifications of the radio to be used in the Car;

(4) Register all such frequencies, including primary and backup Car frequencies, with the INDYCAR-designated representative at each Event a minimum of 24 hours prior to the start of an Event.

(5) Notify the INDYCAR designated representative immediately upon changing primary Car or crew to frequency;

(6) Operate all such frequencies in the 450 – 470 mhz UHF spectrum with a 12.5 channel spacing;

(7) Not encrypt or digitize any Car or crew communications on Race day;

(8) Consent, and hereby does consent, to the taping and/or rebroadcast by INDYCAR or its designee of any such transmissions through any and all media and for any and all purposes; and

(9) Comply with all applicable laws regarding such use, and indemnify and hold INDYCAR and its designees harmless with respect to failure to comply with applicable laws, even if the violation involves INDYCAR's or its designee's sole or contributory negligence.

B. Wireless Data Frequency (“WiFi”) – Each Member transmitting or receiving any signals for wireless data transmissions shall:

(1) Register the frequency and sub-level channels with the INDYCAR-designated representative at each Event a minimum of 24 hours prior to Cars on the Track at each Event.

(2) Notify the INDYCAR-designated representative immediately upon changing frequencies or sub-level channels;

(3) Coordinate and modify frequencies for use with other wireless data networks as specified by INDYCAR; and

(4) Comply with all applicable laws regarding such use, and indemnify and hold INDYCAR and its designees harmless with respect to failure to comply with applicable laws, even if the violation involves INDYCAR's or its designee's sole or contributory negligence.

4.4 Car Registration- A Car may compete only in the Events in which the Car is entered. The Entry form must establish the Entrant's right to enter the Car in the Event and include proof of ownership of the Car acceptable to INDYCAR upon request. After receipt of the Entry form, INDYCAR may examine the Car. INDYCAR will use two unique numbers to identify the Car:

A. Registration Number (serial number) – The unique number assigned by the chassis Manufacturer.

B. Car Number – INDYCAR will assign to each Entrant License (not Driver License) a unique Car number (not to exceed two digits, with the exception of Car number 100). Car numbers 1 and 01 will be reserved for the defending Entrant (not Driver) series champion.

(1) All Car numbers are owned by INDYCAR. No Member has a right to or ownership interest in a Car number. An Entrant may not sell or assign a Car

number without the prior written consent of INDYCAR.

(2) Assignment, or reassignment, of Car numbers is in the discretion of INDYCAR and may not be protested or appealed. All Entrants desiring a particular Car number must make a written request. INDYCAR will not guarantee a request will be granted.

(3) After a Car number is assigned to a particular Entrant License, it will remain with that Entrant License until the end of the season, provided that Entrant enters a Car and displays the Car number on the Car at each Event. If the Entrant does not enter a Car and/or display the Car number on the Car at an Event, INDYCAR may reassign the Car number.

(4) The required numbers must be clearly visible as determined by Officials. All aspects of the Car number including but not limited to width, color, font and slant must be approved by INDYCAR prior to use. Unless otherwise approved by INDYCAR, the required Car number areas must be free of all other decals, trim and decorations.

(5) Each Car must provide the following minimum size rectangular "blank space" areas in specific locations for the display of required Car numbers of specific minimum sizes.

(a) Left and Right Rear End Fences –The minimum height of the Car number must be 11 inches. **(See Illustration).**

(b) **Nose** – The Car number must be 9 inches tall. The Car number must be located in an INDYCAR-approved location. (See **Illustration**).

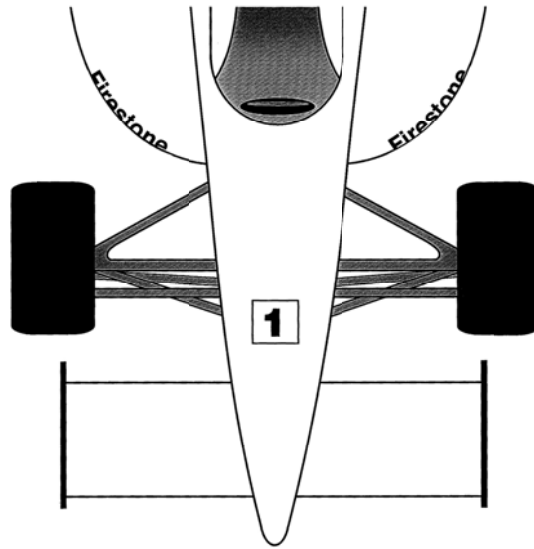

(c) **Attenuator** - The Car number must be 3 inches tall (**See Illustration**).

(i) **Rookie Driver** - Each Car must display a red Car number on a white background.

(ii) **Veteran Driver** - Each Car must display a black Car number on a white background.

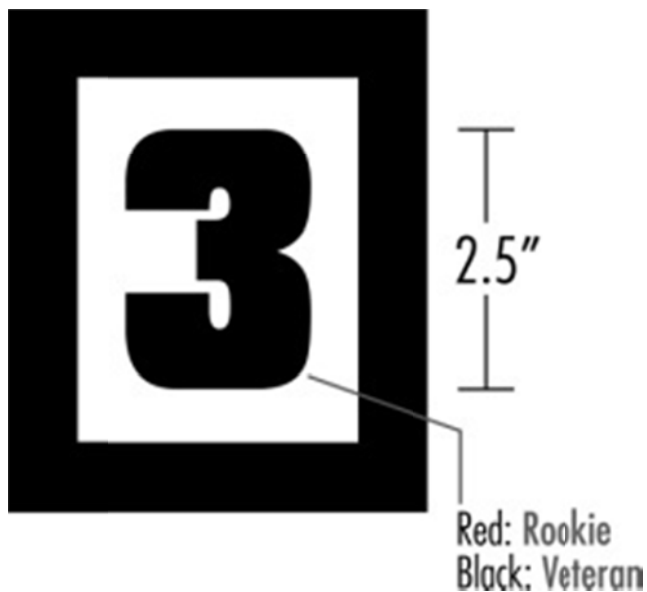

(d) Headrest - The Car number must be a minimum dimension of 1 inch by 1 inch. The Car number must be located on top of the headrest behind the Driver's helmet with black numbers on a white background (See **Illustration**).



(e) **Tub** - The Car number and Driver's first and last name must be 1 inch tall each. They must be located directly behind the headrest and on the tub and appear in white lettering (**See Illustration**).



(6) Car Names - A Car must have a name that shall be identified on the Entry form. The Entrant represents to INDYCAR that it has the right to use that Car name. The Car name is subject to the approval of INDYCAR and must not exceed 35 characters, including all spaces and punctuation.

(7) Car Appearance – INDYCAR has the right to control the appearance of Cars to distinguish one Car from another. This may include but is not limited to Car color. Cars are required to display significantly different colors. In general, INDYCAR may require different color schemes on any four of the following seven components:

- Mirror housing;
- Air intake;
- Roll hoop camera cover;
- Front and rear wing end fences;
- Leading edge of the front wing;
- Leading edge of the rear wing; or
- Attenuator.

V.
ENTRIES

5.1 General – All Entry applications shall be completed on forms provided by INDYCAR in the form required by INDYCAR and shall be subject to the approval of INDYCAR. Entries are not transferable without the prior written approval of INDYCAR.

A. An Entry consists of an Entrant, Driver and numbered Car.

(1) Entrant -

(a) An approved Entry serves as the authorization to compete in a specific Event(s) on behalf of the specific Entrant to whom the Car number is assigned.

(b) If an Entrant participates in an Event without having properly submitted a fully-executed Entry form, the Entrant, by such participation, nevertheless agrees that the Entrant is subject to all Rules, and all statements, releases and obligations appearing in the Entry form for the Event, as if the Entrant had properly submitted a fully-executed Entry form.

(2) Driver -

(a) Each Entry form must list a Driver.

(b) Another Driver may be substituted for the original Driver, provided notification is given to INDYCAR, and INDYCAR approves the substitution. Approval may be granted or

withheld in the discretion of INDYCAR.

(3) Car -

(a) Participation of a Car in an Event - In order to participate in an Event, the Car must be properly entered and be designated and explicitly identified by Car number on only one Entry form for that Event. Any Car participating in an Event while in noncompliance with the above requirements may be disqualified, and any Competitor who causes such noncompliance may be disqualified and/or otherwise penalized by INDYCAR.

(b) Car Substitution during an Event (“Backup Cars”) - Another Car may be substituted for the entered Car provided the substitution is made, notification is given to INDYCAR and approval is granted by INDYCAR.

5.2 Fee – Entry fees must be paid as directed by INDYCAR.

5.3 Deadline - The Entry deadline shall be stated on the Entry form. Unless otherwise specified on the Entry form, the hour of closing shall be 5 p.m. E.D.T. INDYCAR may accept or refuse to accept late Entries. Late Entrants, if accepted, may be penalized by INDYCAR.

5.4 Electronic Entries - An Entry by computer, facsimile or other means delivered by the Entry deadline may be accepted in INDYCAR’s discretion, provided it is subsequently accompanied by the original completed Entry form and Entry fee within 48 hours of INDYCAR’s receipt of the electronic Entry or as otherwise directed by INDYCAR.

5.5 Reopening of Entries - If INDYCAR postpones an Event, INDYCAR may authorize the reopening of Entries. Reopened Entries shall close not less than 48 hours before the declared starting time of the postponed Event.

5.6 Failure to Participate - Any Driver, Entrant or other Member who by Entry form or other means has agreed to participate in an Event may be penalized for failing to participate.

5.7 Entry Change – All changes to an approved Entry form shall be completed on INDYCAR provided forms and subject to approval by INDYCAR prior to the Entrant's Car participating in any Track activities.

VI. TESTING

6.1 In General – Members are only permitted to conduct Testing in accordance with this Rule VI.

A. “Test” is defined as any period during which a Member conducts any Testing.

B. “Testing” is defined as the use of the chassis, Engine, transmission, and tires, separately or in any combination during a period other than a Race weekend.

C. “Use” is defined as being propelled under power generated by the Engine.

6.2 Approved Testing –

A. “Open Test” – An Open Test is a Test organized by INDYCAR to which all Entrants are invited to participate. It includes without limitation the following:

- a. **Barber** – 1 day on Track
- b. **Kentucky** – 1 day on Track
- c. **Indianapolis** - 1 day on Track

B. “Manufacturer Test” – A Manufacturer Test is a Test organized by a Manufacturer to which selected Entrants are invited to participate.

C. “Private Test” – A Private Test is a Test organized by an Entrant and subject to the following restrictions.

(1) Entrants will be permitted Private Tests from

January 15, 2011 up through and including
March 23, 2011.

(2) Prior to a Test, Entrants must submit a Testing Request Form to INDYCAR a minimum of 14 days prior to the Test. Cancellations must be received a minimum of 72 hours prior to the Test. Once the Test has been approved, INDYCAR will notify the Engine builder and tire Manufacturer.

(3) Driver Eligibility – Any combination of Drivers may participate in a Private Test. The Driver is not required to be the Entrant's current Driver. The Driver must be a pre-approved Firestone Indy Lights Driver.

(4) Amount of Testing – Each Team will be permitted 2 Private Test days to be used between the first and last Races, with the exception of Rookie Drivers who will be permitted 4 Private Test days. Each Entrant may purchase a maximum of 2 sets of tires per Test day.

D. "Bonus Miles" – A Firestone Indy Lights Driver may be eligible to participate in IZOD IndyCar Series bonus Miles pursuant to the IZOD IndyCar Series rules.

E. "Rookie Test" – Unless otherwise approved by INDYCAR, all rookie orientation tests must take place at Kentucky Speedway on May 10, 2011. Each Driver is expected to have completed a minimum of 300 Testing miles prior to the Rookie Test. Any Rookie Driver joining Firestone Indy Lights after May 10, 2011 will be addressed on an individual basis.

F. Testing By New/Partial Season Entrants – Entrants joining Firestone Indy Lights after the first Race may be allowed Testing at the discretion of INDYCAR.

G. INDYCAR-Approved Venues – Tests may only occur at the following INDYCAR-approved venues:

- (1) All 2011 Firestone Indy Lights Race venues, except Indianapolis Motor Speedway and street course venues
- (2) Firebird East Test Track
- (3) Phoenix International Raceway (Oval)
- (4) Homestead Miami Speedway (Oval/Road Course)
- (5) Sebring International Raceway (Road Course)
- (6) Houston Motorsports Complex
- (7) Palm Beach International Raceway
- (8) California Speedway
- (9) Michigan International Speedway
- (10) Nashville Superspeedway
- (11) Richmond International Raceway
- (12) Kansas Speedway (Oval)
- (13) Chicagoland Speedway (Oval)
- (14) Watkins Glen International
- (15) Putnam Park
- (16) Autobahn (Short Course)

(17) Infineon Raceway

This Rule does not apply to Open Tests (which shall be conducted only at venues designated by INDYCAR).

H. Testing Periods – In general, Testing is not permitted at a facility where a Race is being held within 7 days prior to the start of the Race weekend. (e.g., First practice Friday / testing concludes end of the day Thursday week prior). In addition, Testing is not permitted on the following days:

- (a) January 1, 2011 - January 14, 2011
- (b) April 30, 2011 – May 1, 2011
- (c) May 14, 2011 - May 15, 2011
- (d) May 21, 2011 – May 22, 2011
- (e) May 28, 2011 – May 30, 2011
- (f) June 3, 2011 – June 5, 2011
- (g) September 13, 2011 – September 21, 2011
- (h) October 3, 2011 – October 10, 2011
- (i) November 22, 2011 – November 29, 2011
- (j) December 15, 2011 – December 31, 2011

6.3 Additional Testing Restrictions –

A. Members agree to provide a minimum of one hour of media availability per Test day.

B. Test Days may not be assigned, sold or otherwise transferred to another Team.

C. Except as otherwise provided by INDYCAR, any Member Testing at a facility must permit other Members to Test at the facility on the same date (up to the maximum number permitted by the facility).

D. Testing requests for any purpose other than as set forth in this Rule VI (for example, for filming commercials) must be submitted to INDYCAR for approval. If a Test is approved, INDYCAR may establish conditions for approval including without limitation requiring the presence of an Official.

E. Members shall not Test in simultaneous on-Track activity with any non-Firestone Indy Lights vehicles (including without limitation IZOD IndyCar Series cars).

F. An INDYCAR approved testing facilitator must be present at all Tests.

VII. ON TRACK PROCEDURES

7.1 General

A. Track Condition - The Race Director determines the Track Condition.

1.Track Conditions include the following:

a.Green Condition - The green condition signifies racing conditions.

b.Yellow Condition – The yellow condition signifies caution.

i.Oval Events – All Cars must slow down.

a.Practice - The Drivers shall reduce speed immediately, maintain position, yield to safety vehicles and/or personnel and return to their assigned pits. All times posted during the lap shall be voided.

b.Qualifications - A qualifications attempt is stopped.

ii.Road/Street Course Events

a.Local – Drivers should reduce speed and be prepared to stop. Passing is not permitted between the first yellow condition and the subsequent green condition.

b.Full Course - Waving double yellow flags is greater danger. Racing ceases. Drivers must reduce speed immediately. During practice and qualifications, all times posted during the full course yellow condition shall be voided.

3.All Events – During a Race

a.All Drivers are required to slow to caution speed, at which time the Safety Car will pick up the leader. All other Drivers are required to form a single file line, nose to tail (“packing up”) behind the Race leader. The Race Director in his discretion shall determine if the leader or any other Car fails to pace the Race as directed. The Race Director in his discretion shall determine the type and timing of any penalty as he deems appropriate. Such decision is not subject to protest and/or appeal.

b.Upon the commencement of a yellow condition, the pit lane shall remain open unless otherwise announced by Race Control. Any Cars entering the pit lane under the yellow condition must maintain their relative position to Cars on Track and shall restart at the rear of the field. Any Driver at or past the pit commit line prior to commencement of the yellow condition may make a pit stop and exit the pit lane with caution.

c.The pit lane will start and end at points designated by Officials. The pit entrance and pit exit lanes are considered part of the Track. Drivers exiting the pit lane shall rejoin the pack relative to the position they are to the Safety Car and/or Cars on Track

as they cross the blend out line. Taking improper position upon leaving the pit lane or failure of a Driver and/or Entrant to follow the direction of Officials may result in a minimum one lap penalty. The Official's determination of the order is not subject to protest or appeal.

d. A Car may not use pit lane to improve its position relative to the Safety Car or any Car remaining on the Racing Surface, but a Car may improve its position relative to other Cars in pit lane.

e. Laps completed will be scored, unless stated otherwise by Officials.

c.Red Condition – The red condition signifies that racing conditions are no longer in effect.

i. Competitors must proceed cautiously to a location designated by Officials.

ii. Unless otherwise instructed by Officials, no work is permitted on the Cars, except Entrants may plug in a booster battery and apply towels to bodywork.

2. The decision as to whether to declare a green, yellow or red condition may not be protested or appealed.

3. While additional information regarding Track Condition is included in the Flag Code section for convenience, this information is equally applicable to the other systems of notification (Track Lights, Race Control Frequency and Track Condition Radio).

B. Decisions by the Race Director are effective at the time he declares his decision, regardless of the time the

declaration is received by the Competitors. INDYCAR uses multiple systems to notify Competitors of such decisions. All Competitors shall react to the first notification they receive. The systems include the following:

1. Track Lights – Green and/or yellow lights positioned around the Track above the outside retaining wall adjacent to the debris fence.

1. “Race Control Frequency” – The radio frequency used by INDYCAR to provide direct communication to Entrants during Events. The spotter (if applicable) and a representative of the Entrant in the Entrant’s pit must both monitor it. Entrants failing to monitor it shall be charged with knowledge of communication on such frequency and are subject to penalty. Competitors failing to follow directions may be penalized.

2. Track Condition Radio (“TCR”) - All Cars must use the INDYCAR-supplied TCR and wiring harness without modification.

a. Oval Events - The TCR signals a yellow condition.

b. Road/Street Course Event - The TCR signals a full course yellow or red condition.

3. Flag Codes (“Flags”) -

a. Green: signifies a green condition.

i. All Events

i.Practice – A practice session has begun.

ii. Qualifications - A qualifications attempt or segment has begun.

iii. Race – Unless otherwise instructed, a Race has begun.

ii. Road/Street Course Events Only - The Track downstream of a yellow condition is clear.

b. Yellow: signifies a yellow condition.
During Road/Street Course Events:

i. **Local** – A stationary yellow flag is shown at a marshal's post.

ii. **Full Course** - Double yellow flags shown at a marshal's post.

c. Black - The Driver shall proceed to the pit area on the next lap and follow the instructions of Officials.

i. The Race Director may declare a black flag for a Car if he determines that:

a. Any condition exists which could cause the Driver or the Driver's Car to create a hazard to the Driver or others;

b. Upon request by the Entrant in the event of loss of radio communication;
or

c. If the Driver has violated the Rules.

ii. When a Driver is ordered to the pit lane because of a hazardous condition of the Driver's Car, the proper repairs must be made and approved by Officials before the

Car will be permitted to continue in the Event.

iii.In the event of a violation of the Rules, the black flag may be declared to impose a penalty (a "black flag penalty") which may include repositioning Cars or requiring a Driver to:

a.Drive through pit lane at pit lane speed limits ("drive through");

b.Stop in pit lane ("stop and go"); or

c.Stop in pit lane for a prescribed period ("detention").

iv.The Race Director shall determine the type and length of any black flag penalty. The penalized Car shall proceed to the pit lane as directed by Officials and may return to the Race only upon the declaration of Officials. In the case of a Driver violating the Rules, no work may be performed on a Car during the execution of a black flag penalty. Should any such work occur, the conditions of the penalty are unfulfilled and the penalty procedure must be executed again in its entirety on a subsequent lap. The penalty may not be protested and/or appealed.

d. Black with White Cross - Officials have ceased scoring the Car until further notice.

e. Blue Flag - An approaching Car is attempting to overtake and the Car being signaled must give consideration to the overtaking Driver. Any Driver who fails to yield to overtaking Drivers may be penalized.

f. White

i.Oval Events

1. Qualifications - The Car has commenced its last lap.

2. Race - The leader has commenced the leader's last lap and will continue to be displayed to all successive Cars as they cross the finish line

ii.Road/Street Course Events

1. Practice/Qualifications - A Car is not at speed on the Racing Surface.

2. Race – When displayed from the starter's stand, the leader has commenced his/her last lap and will continue to be displayed to all successive Cars as they cross the finish line.

g. White with Red Cross - Safety vehicles and/or personnel are on Track.

h. Alternating Red and Yellow Stripes - Oil, water or other substance has altered the Racing Surface.

i. Checkered - The practice session, qualifications or Race is completed. The checkered flag will be displayed to the Race leader upon completion of the Race leader's last lap and will continue to be displayed until each Car running has received the checkered flag.

j. Red – signifies a red condition.

1. Unless otherwise declared by INDYCAR, a Race stopped by the declaration of a red condition will be considered incomplete unless more than 50% of the scheduled number of laps has been completed by the Race leader. If INDYCAR schedules the continuation of the Race on a subsequent date or a later time, the Race will be restarted beginning with the unfinished portion of the scheduled number of laps.

2. If a Race is stopped by the declaration of a red condition and more than 50% of the scheduled number of laps have been completed by the Race leader, the Race may be considered complete in INDYCAR's discretion, and final standings will be determined by ranking all Cars in order by total laps completed and sequence of completion through the last official Race lap.

3. Officials will make reasonable effort to restart a Race stopped by the declaration of a red condition if the conditions warrant.

4. The Race Director's decision to restart or not to restart a Race stopped by the declaration of a red condition may not be protested or appealed.

7.2 Timing and Scoring

A. Race Distance and/or Time Limit

1. INDYCAR shall announce the scheduled number of laps and/or time limit prior to the start of a Race.
2. If INDYCAR determines that there are time limitations due to weather, curfew, or otherwise, INDYCAR may move the start time of a Race, shorten the distance of a Race, set a maximum time for a Race, or take such other actions as it deems appropriate in its discretion.

B. Systems

1. The electronic scoring system is the primary scoring record. INDYCAR will record the physical sequence in which each Car crosses the start/finish line, including in pit lane.
2. At Oval Events, the serial scoring system is a backup scoring record.
3. Other substantiating scoring systems may be used at the discretion of Officials.
4. If the Race Director cannot visually determine the position of a Car relative to other Cars, the Race Director may consult with other Officials and access such other data as he determines necessary or appropriate to assist him in determining the order of the Cars.

C. Start/Finish Line - The scoring of Cars shall begin at the moment when the timing transponder of the lead Car reaches the starting line and the declaration of the green or yellow condition has been given by the Race Director.

1. Oval Events - A single start/finish line will be defined across the Track, and extended across the pits where appropriate, in the immediate area of the

starter's stand.

2. Road/Street Course Events - INDYCAR in its discretion may designate separate start/finish lines.

D.Lap Credit

1. A Car will be credited with a lap when its timing transponder crosses the start/finish line after completing one entire lap of the Track with two wheels of the Car remaining on the Racing Surface at all times, as determined from the scoring records. Notwithstanding the foregoing:

a. If a Car returns to pit lane under its own power and retires from the Race, INDYCAR in its discretion may credit the Car with completion of the lap.

b. On the last lap of a Race, a Car will be officially credited with a lap when any part of the Car crosses the finish line.

c. A Car will not be permitted to advance or maintain its position relative to other Cars due to an excursion off the Racing Surface unless the excursion was due to the Car taking evasive action.

2. A Car shall be considered the first Car out of the Race and shall be awarded the final finishing position based on the following order:

a. The Car is a non-starting Car pursuant to Rule 10.3(D).

b. The Car does not leave the starting grid and does not return to the Race,

c. The Car drops out during the parade or pace laps, or

d.The Car drops out of a Race before completion of the first lap.

In the event more than one Car is affected in one of the above categories, INDYCAR shall rank such Cars based on their original starting grid positions.

3. Final standings will be determined by the sequence in which the Cars completed the scheduled number of laps.

a. Except as provided in Rule 7.2(D)(1)(b), a Race will be completed by the Race winner at the moment the timing transponder of the Car crosses the finish line on the last lap. The Race will be completed by each other Car when the timing transponder of each Car crosses the start/finish line after the Race leader. Scoring will thereafter cease, and the Race is completed. Officials' decision may not be protested or appealed.

b.Cars not completing the scheduled number of laps will be ranked in order by total laps completed and sequence of completion, whether the Car is still running or not. The Race Director shall determine the "reason out" for each Car not listed as running. The Race Director's decision may not be protested or appealed.

E.Ties

1.In the event the scorers are unable to conclusively determine any difference in the physical sequence for two or more Cars at the end of a Race, Officials shall determine the finishing positions based upon the Cars' positions at the finish line on the prior lap.

2. In the event two or more Cars post the identical number of laps led in a Race, the Car finishing the Race in the higher/highest position will earn the two points or award for most laps led.

3. The Race Director's decisions are not subject to protest or appeal.

7.3. Pit Assignments, Pit Equipment, Pit Personnel, Pit Access, Pit Procedures, and Pit Penalties

A. Pit Assignments

1. INDYCAR shall make pit assignments based on a rotating system from Race to Race beginning with the point leader at "pit out" and continuing to "pit in".

2. If the Event is the first Event of the season, then the Entrants shall be ranked using the prior season's point standings. INDYCAR in its discretion shall determine an Entrant's eligibility.

3. If an Entrant does not have any points, INDYCAR in its discretion shall make the pit assignment.

B. Pit Equipment - All nitrogen bottles must be securely fastened and have a cage device or protected regulator approved by Officials. All nitrogen bottles must be returned to the designated location at the conclusion of the Event.

C. Pit Personnel -

1. Only individuals associated with an Entrant may be in the Entrant's pit (on the Track side of the pit wall) during a Race.

2. Beginning with the "start your engines" command

and continuing through the conclusion of each Race, a maximum of three crew members are permitted to work on the Car. Crew Members may assume their positions immediately before the Car arrives.

3. Manufacturers' representatives are not considered crew members and will be permitted on the Track side of the pit wall at INDYCAR's discretion.

4. Except as otherwise provided by the Rules, all personnel and equipment must remain within the assigned pit.

D. Pit Access - Cars will not be permitted to enter or exit the garage area under their own power. They must be pushed or towed with a Member in the Car who is able to access the brake pedal at all times.

E. Pit Procedures

1. A speed limit will be enforced during Events within the pit lane areas defined by painted lines, cones and/or other visible markings. The pit speed will not exceed 45 mph.

2. A Driver who passes the Driver's assigned pit by more than one pit must continue around the Track and stop on the next available lap.

3. A Car may not be pushed more than two pits beyond its assigned pit during a Race.

F. Pit Penalties - The following matters and any others which may be determined by the Race Director in his discretion are cause for a Car to be penalized:

1. Failing to follow designated procedures entering or exiting the pit area, including the acceleration and deceleration lanes;

2. Permitting two wheels or more of a Car to leave the designated pit entrance lane, pit lane or pit exit lane;

3. Leaving the assigned pit with air hoses, fuel hoses, air impact wrenches or other equipment attached to or hanging from the Car;

4. Permitting any portion of the Driver's Car to pass over or under any air line or hose or any other equipment;

5. Permitting the Car to come into contact with pit equipment, other Cars and/or personnel outside of standard pit stop procedures;

6. Permitting individuals not associated with an Entrant to be in the Entrant's pit or permitting more than three crew members to work on the Car during a Race; or

7. Permitting the Car to enter a pit other than the Car's assigned pit.

Penalties for violations of this Rule include, but are not limited to, a black flag and/or exclusion from the Event. No such decisions may be protested or appealed.

7.4 Race Start

A. All Drivers must place their Cars in their respective positions on the parade and pace laps. If a Car experiences mechanical difficulty, the Car may return to its original starting grid position any time prior to the conclusion of the parade lap. After this time, the Car shall be moved to the rear of the starting grid. If more than one Car is so affected, the Race Director shall determine the order at the rear of the starting grid as he deems appropriate in his discretion. The remaining Cars in the field must maintain their assigned positions unless otherwise instructed by Officials.

B.Cars dropping out on the parade or pace laps may be considered cause for delaying the start. Such Cars will be directed to the pit lane or another designated area and will be permitted to join the Race under the direction of Officials whenever their difficulty is corrected. Unless otherwise instructed, their first scored lap must begin at the starting line on the Racing Surface.

C.A Safety Car will be used to pace the field at the start of the Race. The Safety Car will have its flashing lights on during the parade and pace laps. At the appropriate time, the lights will be turned off, indicating intent to start the Race the next time across the starting line. The Safety Car will pull off into the designated location. The lap count may begin at the conclusion of the pace lap.

D.After the green condition is declared, all Drivers must maintain their relative positions until crossing the starting line. If a Driver improperly improves his/her position without cause prior to crossing the starting line, the Driver may be penalized. The imposition or non-imposition of a penalty may not be protested or appealed.

E.Upon the Race Director's declaration, all Cars must start a Road/Street Course Race on "wet tires". While changes may be made to the Cars on the grid to accommodate the "wet tires", the Entrant remains responsible for complying with post-Race technical inspection. After such a declaration has been made, Entrants may change to dry tires at their discretion.

7.5. Race Restart

A. After a Yellow Condition

1. When the Track is clear for racing, the Safety Car will assist the field in preparing for a restart. At the appropriate time, the flashing lights will be turned off, indicating intent to restart the Race the next time across the starting line, and the Safety Car will accelerate away from the field, and pull into the designated location. The Race leader is required to maintain pace lap speed until reaching a point designated by INDYCAR to accelerate smoothly back to racing speed and the green condition will then be declared. The Race Director in his discretion shall determine if the leader or any other Car fails to restart the Race as directed. The Race Director in his discretion shall determine the type and timing of any penalty as he deems appropriate. Such decision is not subject to protest and/or appeal.

2. The Race Director in his discretion may move lapped Cars to rear of the field prior to a restart.

3. During the yellow condition, no Car may pass another Car unless:

- a.** The other Car is stopped on the Track or the Driver of the other Car has waved all of the passing Cars by in a safe location and promptly confirms such action by radio communication to Officials;
- b.** The other Car is not maintaining the pace lap speed; or
- c.** Either Car is in the pit lane boundaries.

The penalty for passing the Safety Car or another Car during a yellow condition without authorization by Officials shall be a black flag, lap(s) or such other

penalty as Officials deem appropriate. A position ranking penalty assessed for passing during a yellow condition is discretionary and may not be protested or appealed.

B. From a Red Condition

1. The Cars will be lined up in single file order beginning with the Race leader. The restart order of the remaining Cars will be determined by their physical sequence at the start/finish line during the last scored Race lap.

2. Notwithstanding Rule 7.5(B)(1), the following reasons may be cause for a Car to be placed at the rear of the restart lineup:

a. Cars involved in a crash during, or subsequent to, the last scored lap. The decision as to whether a Car has been involved in a crash may not be protested or appealed.

b. Cars stopped on the Track, including the pits, during the last officially scored lap.

The restart order of Cars placed at the rear of the lineup will be in order by total laps completed and sequence of completion.

3. Any laps being run under a yellow condition will be scored. Any Cars remaining in pit lane at the time of a restart may join the Race if approved to compete by Officials.

7.6 Hazardous Mechanical Conditions

A. Officials shall determine whether a Car involved in a crash or with a hazardous mechanical condition will be permitted to continue in the Event or must first return to the pit lane or the garage area for necessary repairs.

B.Officials shall determine how the Car is removed and where the Car is taken. INDYCAR is not responsible for payment, reimbursement, damage or loss to any Car as a result of such removal.

C.After any repairs have been completed by the Entrant's crew, the Car is subject to visual or other inspection by Officials prior to and/or during any further competition. If Officials determine that further repairs are warranted, the Entrant's crew must make those repairs before the Entrant's Car is permitted to return to competition. Cars being repaired will be permitted to return to a Race at the discretion of the Race Director.

D.Officials may approve or disapprove technical or structural changes between the Race start and the post-Race inspection due to contact or material or parts failure.

E.A Car may only receive on Track assistance as directed by INDYCAR.

F.These decisions are in Officials' discretion and may not be protested or appealed.

7.7 Performance Standards – The Race Director in his discretion may establish a performance standard which all Entries entered in an Event must achieve in order to participate in the Event . In general, Entries must perform within 105% of the Car posting the best time and demonstrate Car consistency, control/placement and interaction with other Cars on track to the satisfaction of the Race Director. In general, the standard will be announced to all Competitors prior to the start of the first practice session and will not be raised after practice has started. However, INDYCAR in its discretion may delay announcement of the standard until a later time based on the physical condition of the Track, safety and other considerations.

VIII. QUALIFICATIONS

8.1 All Events – This Rule 8.1 contains qualifications rules for all Events.

A. Overview - Qualifications determines the eligibility and starting position of each Car desiring to participate in a Race by ranking the Car on the basis of its performance in qualifications.

B. Meeting – INDYCAR may hold a specific meeting prior to the start of qualifications. INDYCAR may designate the meetings as mandatory for some Members.

C. Starting Time / Delays/ Interruption and Suspension / Performance Standards

(1) Starting Time - The Race Director shall determine the starting time for the qualifications period.

(2) Delays - The Race Director may penalize any Member attempting to delay qualifications.

(3) Interruption and Suspension –

(a) Interruption - Qualifications may be interrupted by the commencement of a yellow condition. Qualifications is interrupted at the moment that the decision to interrupt is made.

(b) Suspension – INDYCAR may suspend qualifications for any reason.

(c) The decision to interrupt or suspend an attempt or qualifications (and reasons therefor) may not be protested or appealed.

D. Technical Inspection

(1) **Fuel** – A fuel sample may be taken from all Cars prior to and after the qualifications attempt. During a qualifications session, no fuel may be added to a Car.

(2) **Impound Area** - Officials shall direct selected qualified Cars to a designated “impound area” to check for compliance. A maximum of two crew members per Car will be permitted in the “impound area”.

(3) **Cars** – INDYCAR reserves the right to seal any component.

(4) **Technical Violations** - If a Car does not successfully complete post-qualifying technical inspection, INDYCAR in its discretion may penalize the Car including without limitation voiding the Car’s qualifying time and placing the Car at the rear of the starting field in accordance with Rule 8.1(F).

(5) **Qualified Cars** - All qualified Cars must remain on the grounds of the Event facility after qualifications unless otherwise permitted by INDYCAR.

(6) **Crashed Qualified Cars** –

(a) If a qualified Car is involved in a crash prior to the Race, INDYCAR in its discretion may permit the Entrant to start either a backup Car or the repaired Car in the Race.

(i) INDYCAR will require the backup Car to start the Race at the rear of the field in accordance with Rule 8.1(G)(2).

(ii) The repaired Car must successfully complete technical and safety inspection and shall start the Race in its original position.

(b) This decision is not subject to protest or appeal.

(c) The Driver of the crashed Car must be approved by Officials in accordance with Rule 1.2(D)(3).

E. Starting Field –

(1) Except as otherwise provided by these Rules, the starting field shall be determined by best time rankings, from fastest to slowest, with the fastest qualifier occupying the pole position, followed by the second fastest qualifier, third fastest, etc., down through the slowest qualifier who has not been “bumped”.

(2) In the event two or more Cars post identical official qualifications times, the Cars shall be ranked in the order in which the completed qualifications attempts occurred.

(3) A Driver who has qualified a Car may not make an attempt to qualify a second Car.

(4) If a Car remains on Track after receiving the checkered flag, INDYCAR in its discretion may penalize the Entry.

(5) The size of the starting fields for each Race shall be determined by INDYCAR.

F. Starting Field Determination –

(1) **No Qualifications/Qualifications Not**

Completed – Not all Entrants have been given an opportunity to qualify. INDYCAR shall assign all starting positions based on the following priority:

(a) Entrant points entering the Event

(b) Blind Draw

If the Event is the first Event of the season, then the Entrants shall be ranked using the prior season's point standings. INDYCAR in its discretion shall determine an Entrant's eligibility.

(2) Qualifications Completed/Open Positions - Qualifications have been completed, but all available starting positions have not been filled. INDYCAR shall assign open starting positions based on the priority in Rule 8.1(F)(1).

G. Subsequent Change in Condition: After qualifications and prior to the start of a Race, an Entry may undergo a change in condition(s) which shall void its qualifications time, original starting grid position and/or practice time. In such case, INDYCAR shall assign the Entry a revised starting grid position(s) at the rear of the starting field based on the following order:

(1) Substitute Starting Engine - An Entrant has an unapproved Engine change pursuant to Rule 14.11(I)(2). The Entrant will start the Race with the same qualified Car and Driver but with a different non qualified Engine.

(2) Substitute Starting Car or Car/Engine Combination – An Entrant has requested and received permission to use a backup Car pursuant to Rule 5.1(A)(3)(b). The Entrant will start the Race with the same Driver but a different non qualified Car or Car/Engine combination.

(3) Substitute Starting Driver – An Entrant has requested and received permission to change Drivers pursuant to Rule 5.1(A)(2)(b). The Entrant will start the Race with the same Car/Engine combination but with a different non qualified Driver.

(4) Alternate Starting Cars – If a Car does not line up for the Race, INDYCAR in its discretion may select the Entrant’s Car posting the next best qualifying time or the next highest Entrant points to complete the field.

(5) Non-Engine Related Penalty (Rule 1.6(B)(2)(b) and Rule IX) – An Entrant or Driver has been penalized and moved to the rear of the starting grid.

(6) Non-Starting Cars (Rule 10.3(D)) – A Car does not line up for the Race.

If more than one Entry is affected in one or more of the above categories, INDYCAR shall rank such Entries within such category based on the following priority:

- (i) Entrant points entering the Event; and
- (ii) Blind draw.

8.2 Oval Events - This Rule 8.2 contains qualifications rules for Oval Events which are in addition to the rules for All Events contained in Rule 8.1 to the extent not inconsistent with them. In the event of any inconsistency, this Rule 8.2 shall govern Oval Events.

A. Qualifications Order – INDYCAR shall determine the qualifications order by a blind draw. An Entrant’s representative may only draw for a Car entered in the

Event. If an Entrant does not have an authorized representative present at the drawing, Officials may draw for the Car.

B. Qualifications Line -

(1) Cars must be in the qualifications line at the technical inspection area at the designated time.

(2) A Car reserves its position in the qualifications line as long as it remains in the designated position and proceeds with the qualifications attempt when signaled. The Official's decision whether a Car is in its designated position is not subject to protest or appeal.

(3) While the Car is in the qualifications line, an Entrant's representatives may make front wing and tire pressure adjustments only. The Car must be moved as the qualifications line progresses. A Car must not leave the qualifications line without the approval of INDYCAR.

C. Technical Inspection –

(1) INDYCAR may check tire pressures during technical inspection.

(2) If a Car does not successfully complete pre-qualifying technical inspection as determined by INDYCAR in its discretion, the Car shall forfeit its "guaranteed attempt" and may be listed at the rear of the starting field pursuant to Rule 8.1(G)(5).

(4) When a Car is presented for pre-qualifications technical inspection, it must be in the same configuration in which it shall race, with the following exceptions:

(a) The radiator sidepod outlet duct may be

taped or have blanking plates fitted, provided it does not alter the shape of the duct in plan or side view;

(b) Optional wickers may be removed; and

(c) An external battery may be connected to the Car when the Car is in the qualifying line, provided no extension cords are connected to the pit wall or generators.

(5) The Car must remain as presented at pre-qualifying technical inspection throughout the entire qualifications attempt unless otherwise approved by INDYCAR.

(6) Only after a Car's qualifications attempt or post-qualifications technical inspection is completed, whichever occurs later, may any of the foregoing permitted changes be made.

D. Declaration of Intent –

(1) A Car must be presented at the entrance of the “staging pit” when signaled to do so (“declaration of intent”). The Race Director shall signal a Driver when it is time for the Car to depart from the qualifications line to begin a qualifications attempt. Unless otherwise provided by the Race Director, each Car must depart the qualifications line within 60 seconds of receiving the signal.

(2) In order to make an official qualifications attempt, a Car must have been given the signal to depart from the qualifications line and have moved away with the Engine running prior to the end of the qualifications period.

(3) A Car may not be pushed to start its Engine at the start of a qualifications attempt.

E. Warm-Up Laps – A Car shall be given two warm-up laps.

(1) At the Indianapolis Motor Speedway, a Car shall be given one warm-up lap.

(2) At any Event, the Race Director in his discretion may add additional warm up laps as he deems appropriate.

F. Qualifications Attempt –

(1) Qualifications will be based on one individually-timed attempt per Car. A qualifications attempt is the total of two consecutively timed laps.

(2) Each Car will be permitted only one departure from the qualifications line to commence its qualifications attempt. A qualifications attempt may only be started and completed under the green condition.

(3) All Cars in the qualifications order shall be given one “guaranteed attempt” to qualify. Notwithstanding the foregoing, the following matters and any others which may be determined by the Race Director in his discretion are cause for a Car to forfeit its guaranteed qualifications attempt and to be listed at the rear of the starting grid in accordance with Rule 8.1(F):

(a) A Car is not presented in the proper order at technical inspection at the designated time;

(b) A Car does not successfully complete technical inspection;

(c) A Car is not presented in the proper order at the staging pit at the designated time;

(d) A Car fails to leave the staging pit within the designated time;

(e) A Car leaves the staging pit but fails to receive the green flag; or

(f) A Car fails to receive the checkered flag.

If more than one Car is so affected, the Cars shall be ranked according to Rule 8.1(F).

(4) If the qualifications period concludes before each Car has been given its “guaranteed attempt”, then qualifications shall resume at a time designated by the Race Director, if practicable. If the Race Director in his discretion is unable to resume qualifications and allow each Car its guaranteed attempt, the entire starting field shall be determined in accordance with Rule 8.1(F).

(5) If Officials interrupt qualifications for reasons caused by a Driver or the Driver’s crew, the Driver’s Car shall forfeit its guaranteed qualifications attempt and may be listed at the rear of the starting grid in accordance with Rule 8.1(F). If the interruption is not due to the actions of the Driver or the Driver’s crew, the Car shall not be charged with its qualifications attempt and the Car may be permitted to return to its position at the front of the existing qualifications line and proceed with its guaranteed qualifications attempt.

(6) If a Car has started its warm-up laps or its qualifications attempt when qualifications are suspended, the Car will not be charged with an attempt and will be returned to its position at the front of the existing qualifications line when qualifications resume. Officials shall preserve the qualifications line already established when qualifications resume. If Officials release a Car

during a suspension, the Entrant is not required to keep its Car at the designated location during the suspension. Officials shall announce prior to resuming qualifications that all Cars are to be returned to the designated location. Any Entrant not returning an Entrant's Car to the designated location by the designated time shall forfeit the Entrant's guaranteed qualifications attempt and may be listed at the rear of the starting grid in accordance with Rule 8.1(F).

8.3 Road/Street Course Events – This Rule 8.3 contains qualifications rules for Road/Street Course Events which are in addition to the rules for All Events contained in Rule 8.1 to the extent not inconsistent with them. In the event of any inconsistency, this Rule 8.3 shall govern Road/Street Course Events.

- A.** Qualifications shall consist of one group unless announced by bulletin prior to the Race weekend.
- B.** INDYCAR in its discretion may elect to divide qualifying into two groups. In such case, all Cars shall participate in one of two groups for 20 minutes per group inclusive of full-course yellow conditions. The groups shall be determined by a blind draw. Each group shall be ranked in order of time as follows:
 - 2.** The fastest overall time from the two groups shall start from the pole position. All other Cars in the same group shall occupy the odd numbered positions, and
 - 3.** The fastest overall time from the other group shall start from position 2. All other Cars in the same group shall occupy the even numbered positions.
- C.** If a Car causes a red or full course yellow condition or otherwise interferes with qualifications as determined by

the Race Director in his discretion, the Car's best timed lap of the session shall be disallowed.

D. If a Car causes two red or full course yellow conditions or otherwise interferes with qualifications as determined by the Race Director in his discretion, all session times shall be voided, and the Car shall not be permitted to participate in the remainder of qualifying.

E. During a local yellow condition, a Driver may not improve his/her lap time if the Driver has yet to pass through the local yellow area.

F. The polesitter may elect to start from either front row position. The Driver must notify the Race Director of this decision prior to the pre-Race Driver's meeting.

IX. PENALTIES

9.1 General – The Race Director may penalize any Member for any violation of the Rules. If an Official observes or is made aware of an act or omission by a Member that constitutes a violation of the Rules and if the Official determines that the act or omission is sufficiently serious to warrant the imposition of a penalty, the Official shall promptly report the violation to the Race Director. The Race Director shall consider the report and shall conduct whatever additional inquiry he deems appropriate under the circumstances. After concluding the inquiry, the Race Director shall determine whether disciplinary action is appropriate, and if so, what disciplinary action should be taken. The Member shall be informed of the determination, and if disciplinary action is imposed, the Race Director shall issue a Penalty Notice to the Member specifying the violation, a brief statement of the circumstances of the violation, and the penalty imposed. If the act or omission of a Member is determined by the Race Director to constitute a threat to the integrity of INDYCAR, Firestone Indy Lights or to the orderly conduct of an Event or to constitute a violation during an Event, the Race Director may take immediate action against the Member.

9.2 Scope of Penalties - Penalties for violations of the Rules are divided into two categories: Race Procedure Penalties and Non Race Procedure Penalties. Regardless of the category, penalties are determined by the gravity of the violation and its effects on fairness of competition, the orderly conduct of the Event, and the interests and integrity of automobile racing, INDYCAR and Firestone Indy Lights. The Race Director shall have the authority to impose any or all or any combination of the following penalties against any Member for any violations of the Rules at any time:

A. Race Procedure Penalties are a result of on Track conduct and are generally imposed during on Track

activity. If the imposition of a penalty is near or at the end of an on Track activity and the Driver/Car does not fulfill it, the Race Director may reposition the Driver/Car in the posting of results to reflect the fulfillment of the penalty. The penalty including without limitation any repositioning in a posting is non-protetable and/or non-appealable.

1.Black Flag - The Race Director may impose black flag penalties.

2.Laps - The Race Director may impose lap penalties. Lap penalties shall be imposed in complete laps only. The imposition of a lap penalty shall result in the removal of official credit for the specified number of penalty laps from the total laps credited to the Competitor, and the scoring records and all points and awards shall reflect the removals.

a.If the lap penalty is imposed during the on Track activity, the removal of official credit shall begin with the Competitor's lap in which the violation occurred and shall include subsequent consecutive laps, as required.

b.If the lap penalty is imposed after the on Track activity is completed, the Race Director shall determine, based on the severity of the violation, whether the removal of official credit shall begin with the Competitor's last lap and include previous consecutive laps as required, or begin with the Competitor's lap in which the violation occurred.

The Race Director shall make a reasonable effort to notify the penalized Competitor of a lap penalty at the time it is determined. However, failure to notify the Competitor during the on Track activity will in no way mitigate or change the penalty.

3.Time – The Race Director may impose time

penalties. The time penalty is the loss of time to participate in on Track activity including but not limited to open or private Test, practice session or qualifications period. The time penalty must be fulfilled when directed. The time penalty begins when the Member, the Member's Car and Entrant personnel are in pit lane.

4.Disqualification - The Race Director may impose a sentence of disqualification. A sentence of disqualification shall entail the loss of any right to compete in the remainder of the current Event from the time at which the disqualifying condition first occurred. It may entail the forfeiture of Entry fees paid or payable, and the Race Director shall determine, based on the severity of the violation, whether or not the sentence includes the forfeiture of points and awards earned up to the moment at which time the infraction for the disqualification first occurs.

B.Non Race Procedure Penalties are a result of on or off Track conduct, but they are typically not imposed during on Track activity. They are protestable and/or appealable unless otherwise noted.

1.Additional Appearances and/or Meetings – In lieu of a monetary fine, the Race Director may require a Member to participate in appearances and/or meetings in addition to those required of other Members pursuant to the Rules and any other agreements. The Race Director may specify the due date for completion. Failure to participate may result in reinstatement of the monetary fine.

2.Monetary Fines - The Race Director may issue monetary fines and specify the due date for payment. Unpaid fines may be deducted from any awards payable by INDYCAR to the Entrant or Manufacturer associated with such Member either

before or after the specified due date. The Race Director may suspend or refuse to approve renewal of the License and/or membership of any Member failing to timely pay any fine during the period the fine remains unpaid.

3.Probation - The Race Director may place a Member on probation. Probation is a state of limitation upon a Member's privileges usually following an act or omission occurring before or during membership which calls into question the Member's willingness or ability to abide by standards required for membership. The purpose of probation is to establish a process to allow a Member to prove, by the Member's conduct, that the standards of membership are understood and will be honored at all times. During probation a Member is under heightened scrutiny and the Member can be required to abide by specified standards of conduct which are more stringent than those which are otherwise applicable. If a Member violates probation, the Member is subject to a more severe penalty. The duration and conditions of probation are within the discretion of the Officials.

4.Suspension - The Race Director may impose a sentence of suspension. A suspension may be total or it may be limited to a suspension of membership or License privileges at a particular facility or facilities, or for a particular series of Events, or for a specified or indefinite period of time. Unless expressly limited, a sentence of suspension shall entail the loss of any right to take part in any capacity whatsoever in any Event. Unless otherwise stated, individuals under sentence of suspension will not be issued credentials of any kind for an Event and the privileges and uses of the Track, pit area, and the garage area will be denied. Every suspended individual shall return all credentials and/or Licenses

to the Race Director who will not return them until the term of the suspension has expired. Any delay in surrendering the credentials and/or Licenses shall be added to the term of the suspension. If the suspended individual does not return the credentials and/or Licenses, the credentials and/or Licenses shall be inoperative and invalid until the lifting of the suspension. Suspension may also render void any previous Entry made for any Event occurring during the term of such suspension and may entail the forfeiture of any applicable Entry fees paid or payable for any such Entries. The Race Director shall have the right to reduce, increase or otherwise modify the unexpired term of a sentence of suspension pronounced under the Rules.

5.Loss of Points and/or Awards – The Race Director may rule that a Member who violates the Rules will forfeit all or a portion of the points and/or awards earned in that year, including points and awards earned in the Event in which the violation occurred.

9.3 Additional Provisions and Guidelines

A.Improper Conduct - Any Member attempting to or engaging in unsportsmanlike conduct or conduct detrimental to racing, INDYCAR and/or to Firestone Indy Lights, whether during an Event or on or off the Track, may be subject to any or all penalties. Improper conduct shall include without limitation:

- 1.**engaging in reckless, careless, and overly aggressive actions or unsportsmanlike behavior toward other Members,
- 2.**impeding the conduct of an Event, including Car control, placement and inconsistent driving pattern,
- 3.**causing an avoidable yellow or red condition,

4. endangering the safety of Competitors,

5. failing to participate at competitive speed,

6. failing to participate in close proximity to other Cars,

7. failing to follow the direction of Officials, and

8. using improper, profane or disparaging language or gestures in reference to Officials, Members or actions or situations connected in any way with INDYCAR, Firestone Indy Lights or any Event.

B.Blocking – A Driver must not alter his/her racing line based on the actions of pursuing Drivers or use an abnormal racing line to inhibit or prevent passing. Blocking will result in a minimum of a black flag “drive through” penalty.

C.Avoidable Contact – A Competitor must not initiate or attempt to initiate avoidable contact that results in the interruption of another Competitor’s lap time or Track position.

D.Team Tactics and/or Orders – Team tactics and/or orders on the Track are prohibited. If the Race Director determines one or more Members of a Team attempted to or engaged in team tactics or orders, the Race Director may issue a black flag penalty to any or all of the Team’s Car/Driver combinations in addition to other penalties.

E.Assault or Battery - If any Member shall commit an assault or battery during or in connection with an Event, such Member may be disqualified and/or suspended by the Race Director and may be subject to additional penalties.

X.
**CHAMPIONSHIPS, POINTS, AND
POINT FUNDS**

10.1 Championships and Point Standings - INDYCAR recognizes several different types of championships, including Entrant and Driver. To facilitate competition for these championships, INDYCAR calculates and publicizes complete rankings of all participating Entrants and Drivers following the completion of each Race. Unless otherwise announced by INDYCAR, all scheduled qualifications and Races shall offer championship points.

10.2 Significance of the Car Number - Points and awards are credited only to the Entrant entered in the Event and to the Driver starting in that Car except as otherwise permitted by INDYCAR. The Car number is listed on the Entry and signifies the Car to be credited. The points and awards accumulate on behalf of the Entrant's License for that Car number, separately from any other Entrant's License that Team may hold.

10.3 Crediting of Points - INDYCAR has established the following system under which eligible Entrants and Drivers may accumulate points.

- A.** Entrant points will be credited only to an Entrant holding a valid Entrant's License at the time of the Event, competing with a properly entered Car and displaying the assigned Car number throughout any Event.
- B.** Driver points will be credited only to Drivers holding a valid Driver License at the time of the Event.
- C.** INDYCAR will not credit that one point usually earned by the Entrant and Driver starting a Race in the pole position if the starting field is determined in accordance with Rule 8.1(F)(1).

D. If a Car participates in practice and/or qualifications but is unable to start a Race, the Driver and/or the Entrant may receive half of the points the Car would have received for the Race had the Car started the Race (“non-starting Cars”). INDYCAR in its discretion shall determine whether a Car is deemed to have participated for purposes of this Rule 10.3(D).

10.4 Ties –

A. At the close of the season, the Entrant and Driver with the highest number of ranking points respectively shall be declared the Champion. In the case of a tie in the championship, INDYCAR will determine the champion based on the most first place finishes. If there is still a tie, INDYCAR will determine the champion by the most second place finishes, then the third place finishes, etc., until a champion is determined.

B. INDYCAR will apply the same system to other ties in the rankings at the close of the season and at any other time during the season.

10.5 End of Season Points Fund - INDYCAR reserves the right to establish an end of season points fund.

10.6 Points – INDYCAR will award points as follows:

<u>Race Finish Pts.</u>	<u>Race Finish Pts.</u>	<u>Race Finish Pts.</u>
1.....50	12.....18	23.....12
2.....40	13.....17	24.....12
3.....35	14.....16	25.....10
4.....32	15.....15	26.....10
5.....30	16.....14	27.....10
6.....28	17.....13	28.....10
7.....26	18.....12	29.....10
8.....24	19.....12	30.....10
9.....22	20.....12	31.....10
10.....20	21.....12	32.....10
11.....19	22.....12	33.....10

Most Laps Led: 2
Pole Position: 1

XI. AWARDS

11.1 Approval - The distribution of all awards must be approved by INDYCAR.

11.2 Awards –

A. INDYCAR in its discretion shall determine the eligibility, nature and amount of all awards for:

- (1) each Event, and
- (2) end of season.

11.3 Withholding–

A. Offset - INDYCAR shall have the right to offset any amounts owed by a Member to INDYCAR, an Event Promoter or a Manufacturer or their affiliates against any awards otherwise payable to the Member or the Member's Entrant.

B. Protest - If a protest is lodged affecting the distribution of an award, all awards and so affected shall be forwarded to the INDYCAR office or in the case of monetary awards placed in an escrow account as directed by INDYCAR within five business days after the filing of the protest, without obligation as to interest.

XII. PROTESTS

12.1 Submission of Protests - A protest shall be submitted to the Race Director.

12.2 Protest – A protest includes:

A. Written Protest - A protest shall clearly state the errors claimed. Each claimed error must be stated in specific rather than general terms and must be accompanied by a written statement of the facts and grounds upon which it is based. Except in the case of penalties that may not be protested or appealed as set forth in these Rules, a Member who receives a penalty notice may file a protest pursuant to Rule XII or, if the penalty was issued by the Race Director, an appeal pursuant to Rule XIII.

B. Protest Fee - The protest fee is \$1,000 and is non-refundable. The protest fee is in addition to any monetary penalty previously assessed.

12.3 Right to Protest and Time Limits -

A. Entry – Only the Entrant submitting an Entry may protest the rejection of such Entry. The protest must be filed within 24 hours of notice of rejection of the Entry. Any Competitor who competes in any Event that is not in accordance with the published Entry form conditions waives the right to protest the non-enforcement of such conditions.

B. Entrant - Only an Entrant may protest an action of the scoring, inspections or awards of positions or an action of the Entrant or another Competitor during an Event. The protest must be lodged within 30 minutes after the official posting of results or the issuance of the penalty notice. To

preserve the right to protest, the Entrant must verbally notify the Race Director of its intent to file a protest within 15 minutes after the official posting of results or the issuance of the penalty notice. If a penalty is not issued until the next business day or later after an Event, the protest must be lodged by 5 p.m. E.D.T. of the second business day following the release of the penalty notice.

C. Other Members - Except as otherwise provided in the Rules, a Driver or other Member may protest any action taken by Officials with respect to such Driver or Member. Protests of actions taken by Officials must be lodged within 30 minutes after the official posting of results or the issuance of the penalty notice. To preserve the right to protest, the Driver or other Member must verbally notify the Race Director of the Driver's/Member's intent to file a protest within 15 minutes after the official posting of results or the issuance of the penalty notice. If a penalty is not issued until the next business day or later after an Event, the protest must be lodged by 5 p.m. E.D.T. of the second business day following the release of the penalty notice.

D. Any Member who is entitled to protest and/or appeal an issue being protested and/or appealed by another Member is an interested party who has the right to be heard but whose own interest will not be controlled by the protest or appeal decision unless INDYCAR chooses to provide relief at its discretion. Likewise, a Member whose interest may be affected by a protest and/or appeal by another Member has a right to be heard at a protest and/or appeal hearing.

E. Decisions Not Subject to Protest or Appeal - Members recognize the need for Officials to make decisions that require judgment and the exercise of discretion, often instantaneously with Events as they are occurring. Members recognize that there is no system of instant replay during or after an Event. The exercise of judgment by Officials during an Event, and any other

matters which may be designated as not subject to protest or appeal under these Rules, may not be protested or appealed and the decision of Officials is final and binding. Examples of this exercise of judgment include but are not limited to the following:

- (1) Whether to declare a practice session completed or to modify a practice session; whether a Car has participated sufficiently to be deemed a non-starting Car.
- (2) Whether to declare or end a yellow condition; whether, when and where to move a Car.
- (3) Whether a Car must forfeit its guaranteed qualifications attempt; whether to add warm up laps to a qualifications attempt, interrupt a qualifications attempt or to extend qualifications.
- (4) Whether to start a Race on "wet" tires; whether a Car returned to its original starting grid position prior to the conclusion of the parade lap or to reorder the Car at the rear of the starting grid; whether a Driver improved the Driver's position prior to crossing the start/finish line at the start of a Race; whether a Car advanced or maintained its position relative to other Cars due to an off Track excursion; whether a Car retiring from a Race in pit lane shall be credited with completing a lap.
- (5) Whether a Car was properly positioned upon the declaration of a yellow condition; whether the Safety Car signaled a Driver to pass during a yellow condition, whether a proper passing signal was given during a yellow condition, whether the Safety Car or another Car was improperly passed during a yellow condition or whether a Car was properly positioned as it crossed the point designated as the end of the pit lanes.

(6) Whether the Car leading the Race or any other Car fails to restart or pace the Race as directed by Officials.

(7) Whether to declare or end a green condition during a Race.

(8) Whether to declare a black flag, disqualification, or other non-monetary penalty; whether to reposition a Car in a posting to reflect the failure to fulfill a black flag or other penalty; whether a Member attempted to or engaged in unsportsmanlike behavior, blocking or team tactics.

(9) Whether a Car followed proper procedures entering pit lane, participating in a pit stop, or exiting pit lane; whether a Driver passed the Driver's pit by more than one pit and was pushed back to the pit.

(10) Whether a Car successfully completed technical inspection; whether a Car involved in a crash prior to the Race may be repaired or must be replaced by a backup Car and start at the rear of the starting grid; whether a Car is in a hazardous condition or was involved in contact such that it will not be permitted to continue in an Event, or whether to approve technical and structural changes during a Race.

(11) Whether to declare a red condition during a Race, to declare a Car was involved in a crash during or subsequent to the red condition, to restart a Race stopped by the declaration of the red condition, or to rule a Race complete.

(12) Whether a Car caused an avoidable yellow or red condition.

(13) Whether to declare a Race completed, canceled, postponed, temporarily stopped or delayed.

Notwithstanding the foregoing, Officials may review a decision that is non-protetable as they deem appropriate. Review of a non-protetable decision does not render it protetable or appealable.

The Race Director may decline to accept a protest, even if the matter were otherwise protetable, if he determines that the alleged Rule violation is so insubstantial as to not provide a Member with a significant competitive advantage over other Members.

12.4 Jurisdiction - The Race Director shall have the exclusive jurisdiction to resolve all protests. Notwithstanding the foregoing, the Race Director shall have the right, in his discretion, to select an individual or individuals to resolve a protest with all of the powers and responsibilities of the Race Director set forth in this Rule XII. The jurisdiction of the Race Director is limited to those matters and issues submitted to the Race Director by the protestant. The decision which is the subject of the protest shall not be stayed pending the protest unless otherwise determined by the Race Director and upon such terms as the Race Director deems appropriate.

12.5 Advisory Committee – While the Race Director has no obligation to use an advisory committee, the Race Director may choose to use an advisory committee selected by the Race Director to assist in making a determination on a protest. The members of the committee shall consist of individuals involved with automobile racing, but who do not have a financial interest in the outcome of the protest. The advisory committee may make a recommendation as to the disposition of the protest, but any determination is in the discretion of the Race Director.

12.6 Hearing of the Protest – The Race Director may cause an investigation to be made into the matters surrounding the protest and shall convene a hearing within 14 days of receipt of the protest notice unless the hearing date is extended by the mutual agreement of the Race Director and the protestant. The protestant and any Member requesting an opportunity to participate and who the Race Director determines has a

material interest in the protest (as described in Rule 13.4) shall be entitled to be heard and given an opportunity to call witnesses and shall be given adequate notice of the hearing. If a Member is called as a witness and fails to appear, INDYCAR may revoke the Member's membership or otherwise penalize the Member. The hearing shall be informal and shall be confined to the errors claimed in the protest and evidence relevant to those errors. The decision of the Race Director on the protest shall be final and binding on all Members, subject only to the right to appeal the decision under the Rules. Any award withheld as a result of a protest shall continue to be withheld until the protest has been finally adjudicated in accordance with the Rules.

12.7 Compliance with Procedure - Any protest failing to comply with the Rules may be denied and disregarded. Any error not specifically raised in the protest shall be deemed to have been waived.

XIII. APPEALS

13.1 Initiation of an Appeal - To the extent permitted under the Rules, any Member may appeal a determination by the Race Director on the imposition of a penalty or on a protest. An appeal may be initiated by submitting the following to the Senior Official by 5 p.m. E.D.T. of the second business day following the release of the penalty notice or protest decision:

A. Written Notice of Appeal - The notice of appeal must contain reference to the specific action by INDYCAR from which an appeal is taken, the date of the occurrence, the reasons for the appeal, and specific reference to any Rules allegedly violated and the relief requested. The notice of appeal must be accompanied by copies of all written documents pertaining to the appeal, such as protests, responses, rulings, declarations, etc. The notice of appeal must clearly and explicitly state the basis of the appeal.

B. Appeal Fee - The appeal fee is \$7,500 and is non-refundable. The appeal fee is in addition to the protest fee and any monetary penalty previously assessed.

C. Violation Involving Multiple Members – Where more than one Member of the same Entrant is involved in the same violation of the Rules, the Senior Official may at his discretion allow one written notice of appeal and appeal fee to cover all such Members. In order to not lose any rights an Entrant may have, a request under this Rule 13.1(C) should be made and approved by the Senior Official within the two day period.

13.2 Jurisdiction - The Senior Official shall have the exclusive jurisdiction to resolve all appeals. Notwithstanding the foregoing, the Senior Official shall have the right, in his discretion, to select an individual or individuals to resolve an appeal with all of the powers and responsibilities of the Senior

Official set forth in this Rule XIII. The jurisdiction of the Senior Official is limited to those matters and issues submitted to the Senior Official by the appellant. The decision which is the subject of the appeal shall not be stayed pending the appeal unless otherwise determined by the Senior Official and upon such terms as the Senior Official deems appropriate.

13.3 Advisory Committee – While the Senior Official has no obligation to use an advisory committee, the Senior Official may choose to use an advisory committee selected by the Senior Official to assist in making a determination on an appeal. The members of the committee shall consist of individuals involved with automobile racing, but who do not have a financial interest in the outcome of the appeal. The advisory committee may make a recommendation as to the disposition of the appeal, but any determination is in the discretion of the Senior Official.

13.4 Hearing of the Appeal - The Senior Official may cause an investigation to be made into the matters surrounding the appeal and shall convene a hearing within 30 days of receipt of the appeal unless the hearing date is extended by the mutual agreement of the Senior Official and the appellant. The appellant and any Members requesting an opportunity to participate in the proceeding and which the Senior Official determines to have a material interest in the proceeding shall be given notice of the hearing and shall be entitled to be heard and call witnesses. The effect on championship point standings does not constitute a “material interest”. In the Senior Official’s discretion, he may permit a Member to be represented by counsel.

13.5 Conduct of the Appeal Hearing - The hearing will be conducted according to the following procedures:

- A.** The hearing is not open to the public and admittance to the hearing is at the discretion of the Senior Official. The Senior Official shall conduct the hearing in an informal manner.

B. The Senior Official shall identify the parties and other necessary participants in the proceedings. The Senior Official may summon any Member to testify at the hearing.

C. The Senior Official may exclude from the hearing room or from further participation in the proceedings any individual who engages in improper conduct in relation to the hearing.

D. The Senior Official shall not be limited to the technical common law rules of evidence required in judicial proceedings but shall be satisfied the evidence submitted is of a type on which the Senior Official can rely. The Senior Official may exclude irrelevant, immaterial or unduly repetitious evidence.

E. All parties to the proceedings shall be permitted to present and cross-examine witnesses and to submit evidence, both oral and documentary. The burden of proof shall remain at all times on the appellant.

F. The Senior Official shall consider only evidence introduced during the hearing and there shall be no transcript of the hearing unless the Senior Official determines otherwise.

G. The Senior Official shall not consider matters not assigned as error in the original protest or matters outside the scope of the submission by the appellant.

13.6 Structure of the Appeal Hearing - The Senior Official shall conduct the hearing in the following manner. Prior to opening statements or the submission of proof by the appellant, the Senior Official may request that the Race Director submit an explanation of the basis of his decision.

A. Opening Statements - The parties to the proceedings will be permitted to make opening statements, with the appellant making the first opening statement. Each party

shall state the issue(s) before the Senior Official and a brief summary of the position of the party with respect to such issue(s).

B. Order of Proof - The evidence shall be received by the Senior Official in the following order:

(1) The appellant shall first submit and present evidence in support of the appeal. Upon the completion of direct examination, each witness shall be subject to cross-examination by the other parties and by the Senior Official.

(2) The Race Director and the other parties shall then be permitted to present evidence, and any witnesses presented shall be subject to cross-examination by the appellant, by other parties, and by the Senior Official.

C. Closing Arguments - Upon completion of the evidentiary portion of the hearing, all parties, beginning with the appellant, may make closing arguments.

13.7 Powers of the Senior Official - The Senior Official shall have the following powers:

A. To call, examine and cross-examine witnesses; to receive and rule upon relevant evidence; to regulate the course of the hearing and, if appropriate or necessary, to exclude individuals or counsel for contemptuous conduct and to strike and disregard all testimony of witnesses refusing to answer proper questions; to dispose of procedural requests, motions or similar matters; to dismiss appeals or portions thereof; to require a party at any time to state its position concerning any issue in the appeal or its theory in support thereof; and to pronounce a just remedy within the Rules for the penalty, result or circumstance at issue.

B. To require the appellant to post an adequate bond to cover the costs of the appeal or any reasonable foreseeable

economic harm to INDYCAR or other Members that might be caused by the appeal. If the Senior Official requires a bond, its form and substance shall be in the discretion of the Senior Official.

C. To order the appellant against whom a final decision is rendered to pay all costs and expenses, including attorneys' fees, incurred by INDYCAR and the other parties if the Senior Official determines the appeal was frivolous.

D. To take any other action deemed appropriate for a just and expeditious conclusion of the hearing.

13.8 Determination of the Appeal – There is no deadline for the issuance of a decision by the Senior Official. The time frame will depend upon the nature of the appeal. It is anticipated that a decision will normally be issued within 30 days.

13.9 Appeal Procedure Final - Decisions of Officials on the interpretation of the Rules, scoring of positions and penalties shall be final and binding unless such decisions and penalties may be protested and/or appealed under the Rules, are protested and appealed within the time limitations and other procedures prescribed by the Rules, and such protests or appeals are pending.

A. A Member's exclusive right to contest a decision or the Rules is within the protest and appeal procedure of INDYCAR, and any decision reached within this procedure is final and binding.

B. Any unappealed protest decision by the Race Director or any appeal decision by the Senior Official on these or any other matters shall be final and binding.

C. No court action of any kind may be taken by any Member.

D. By submitting a membership application and in

consideration of receiving the numerous benefits available, each Member agrees to abide by the decisions of Officials and agrees that such decisions are final, non-appealable (except as provided by the Rules) and non-litigable.

E. Any Member participating in an Event waives any rights such Member may otherwise have to be a party or to take any action in court seeking legal or equitable relief against any decision or action of any kind by INDYCAR, its Officials or anyone acting on behalf of INDYCAR.

F. Each Member acknowledges that participation in an Event by other Entrants, Drivers and Members is in part in reliance on this waiver.

G. If a Member initiates or participates in litigation in violation of the Rules, all membership privileges shall thereupon be suspended and the Member agrees to reimburse INDYCAR, its affiliates, and other named Members for all costs of litigation including without limitation travel expenses and attorneys' fees.

13.10 Compliance With Procedures - Any appeal that fails to comply with any of the foregoing requirements may be dismissed and disregarded. Any error not specifically raised in the protest or appeal shall be deemed to have been waived.

XIV
TECHNICAL SPECIFICATIONS

14.1 General -

A. All components provided by INDYCAR, a manufacturer, a Licensee or an Event Promoter must be used as supplied and without modification. This includes but is not limited to the following:

- (1) Ear Pieces
- (2) Timing Transponders and Covers
- (3) Wiring Harnesses
- (4) Impact Recorders
- (5) Track Condition Radios
- (6) Camera Mounts, Covers and RF Antennas
- (7) Headrest Fasteners/Lanyards
- (8) Licensee Equipment
- (9) Engines
- (10) Rain Lights and Brackets
- (11) Tires
- (12) Road/Street Course Kits

B. If a Rule permits a modification, the request must be made in writing a minimum of 7 days prior to the date of intended use. INDYCAR will approve/deny the request in writing a minimum of 5 days prior to the date of intended use.

C. Tape is not permitted as a single source of attachment for any component unless pre-approved by INDYCAR.

D. Covers, other than bodywork, may only be used on a Car when the Car is in its assigned garage. Notwithstanding the foregoing, rain covers may be used during inclement weather conditions.

E. No form of heating may be used on a Car when the Car is outside its assigned garage.

F. No form of cooling may be used, except cooling towels applied to bodywork and Driver cooling devices.

G. Diapers are mandatory and must be installed for Events.

H. The skid plate as supplied by the chassis Manufacturer or its designee must be fitted to the Car and must maintain a minimum specified thickness of 0.250 inches. The maximum skid plate wear permitted is 0.100 inches. Paint is the only permitted coating. Replacement skid plates can only be purchased from the chassis Manufacturer or its designee. Two additional 0.375 inch diameter holes must be added to facilitate inspection (**See Illustration**).

Skid Inspection Hole Positions

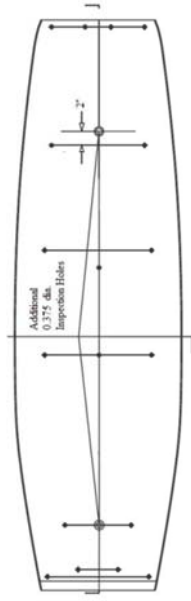

I. Only the INDYCAR approved rain light and mounting must be used.

J. The only approved materials for seals are Teflon, Buna, and Viton.

K. All bearings must be steel. Coatings are not permitted.

L. All oil, water and fuel lines must remain as supplied by the chassis Manufacturer and Engine builder.

M. Two additional fasteners are permitted in each of the following areas: Engine cover, right sidepod and left sidepod. Camloc, DZUS pins and Tridairs are approved fasteners.

N. The technical specifications for Short Oval Events shall apply to Road/Street Course Events, except as otherwise provided.

O. The only options that can be fitted to a Car are those listed in the Firestone Indy Lights parts catalog supplied by the chassis Manufacturer or as permitted by these Rules.

14.2 Inspections -

A. The bottom of the chassis structure or underwing establishes the "chassis reference plane." For purposes of technical inspection, the chassis skid plate and/or the machined bosses on the top of the transmission shall be the measurement reference points.

B. All Cars, parts, equipment and items must complete technical inspection to be eligible for an Event. Officials may inspect all Cars, parts, equipment and items for conformity with the Rules at any time for any reason. Officials in their discretion shall determine what constitutes technical inspection, which may vary by Car and Event.

C. Completion of technical inspection does not guarantee against disqualification or other penalty if any violation is discovered during any subsequent.

D. Officials may impound or confiscate a Car, part, equipment, item or data associated with a Car, a Driver, or an Entrant. Return of a Car, part, equipment, item or data by Officials does not mean that it complies with the Rules.

E. Officials may examine any Car involved in a crash and determine if it is suitable for further participation, and all Members shall cooperate in the preparation of damage reports, photographs, videotaping and impact recording analysis.

F. Any Entrant refusing to allow the Entrant's Car to be inspected or to follow the prescribed inspection procedures may be penalized.

G. INDYCAR is not responsible for payment, reimbursement, damage or loss to any Member as result of inspection procedures, impounding or confiscation.

H. A copy of all required INDYCAR inspection forms must be submitted to INDYCAR for approval before the designated Events.

(I) All parts indicated on any INDYCAR inspection forms or in an INDYCAR bulletin must be tested by the appropriate nondestructive testing techniques or as otherwise directed by Officials. These inspections shall be performed by an INDYCAR-approved inspection station before the following Events:

- (a)** St. Petersburg; and
- (b)** Toronto (except wheels).

INDYCAR may require additional inspections during the season.

(2) The original of all required chassis-repair forms must be submitted to INDYCAR for approval prior to the Car participating in the next Event. Repairs may only be made by the following INDYCAR-approved repair stations:

- (a) Aerodine Composites
- (b) Applied Composites
- (c) EG Composites
- (d) Mark One Composites
- (e) Multimatic
- (f) Indy Composite Works
- (g) JT Composites

I. Aerodine Composites is the only approved installer of the anti-intrusion panels.

J. Decorative chrome plating cannot be used on any parts requiring magnetic inspection. All parts which are painted, plated, or have special coatings must be stripped prior to nondestructive testing and inspection.

K. All stressed parts which have been heated or which have had their shape physically changed must be inspected with the appropriate nondestructive testing method prior to usage.

L. After a crash during a Test, an Entrant must present the following items to INDYCAR:

- (1) Driver's Helmet
- (2) Driver's Head Restraint System
- (3) Driver's Seat
- (4) Chassis Headrest
- (5) Steering Wheel
- (6) Ear Pieces

INDYCAR will inspect the items. At the discretion of INDYCAR, any item that does not successfully complete

inspection must be repaired, re-certified or replaced by the Entrant at the Entrant's cost prior to use.

14.3 Car Size, Car Weight and Driver Equivalency Weight

A. Car Size

- (1) The overall length of the Car shall be 191.5 inches.
- (2) The track width of the Car shall be as supplied by the chassis Manufacturer.
- (3) The maximum wheel base of the Car shall be 117 inches.
- (4) The maximum body width shall be 58.66 inches.
- (5) The rear mainplane height from the chassis reference plane must be a minimum of 31.050 inches and a maximum of 31.250 inches.
- (6) The rear end fence height from the chassis reference plane must be:

Short Ovals/Road and Street Courses

- 1) Minimum of 38.800 inches
- 2) Maximum of 39.000 inches

Speedways

- 1) Minimum of 36.100 inches
- 2) Maximum of 36.350 inches

B. Car Weight –

(1) The overall minimum weight of the Car includes fuel, all lubricants and coolants but does not include the Driver.

(a) Oval Events - 1500 lbs. plus a Driver Equivalency Weight.

(b) Road/Street Course Events - 1530 lbs. plus a Driver Equivalency Weight.

(2) If ballast is utilized to reach the minimum Car weight, it must be securely bolted in the main chassis structure in an INDYCAR approved location.

C. Driver Equivalency Weight

(1) INDYCAR shall determine the additional Driver Equivalency Weight required and shall notify each Entrant by bulletin.

(2) The Driver Equivalency Weight must be obtained as follows:

(a) approved aluminum skid in place of Jabrock, and/or

(b) installed using bobbins inserted in the fuel cell compartment

D. Violation of this Rule 14.3 may result in a minimum \$10,000 monetary fine and/or such other penalties as INDYCAR in its discretion shall deem appropriate.

14.4 Chassis -

A. Vertical Spine –

(1) A vertical spine 0.250 inches minimum height, 0.275 inches maximum height and 0.050 inches (+/- 0.005 inches) thick must be positioned on the Car centerline from the tip of the nose to the most rearward edge of the Engine cover with the exclusion of the cockpit opening, windscreen and camera installation.

(2) Blending of the flanged area is permitted,

provided the vertical spine height remains a minimum of 0.250 inches above the blended area and has no more than 0.062 inch radius at the transition point of the spine. The only spines approved for use are those provided by the chassis Manufacturer.

B. Timing Transponder –

(1) A timing transponder and cover must be located on the left side of the Car in a position determined by INDYCAR. (See **Illustration**).

TIMING TRANSPONDER

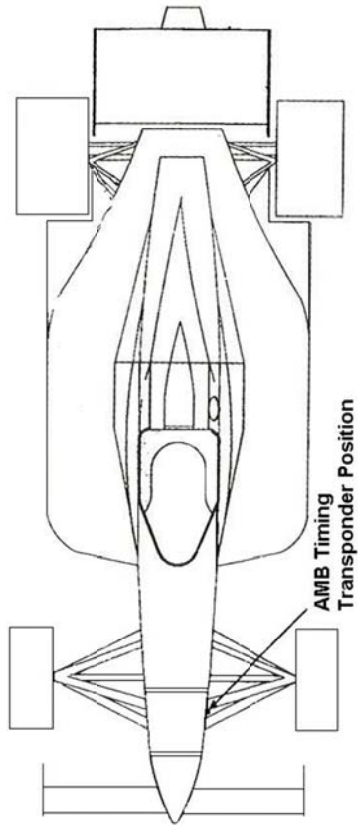

The transponder location is 33.187" from the nose of the Car, and 10" from the reference plane. This is measured off the skid plate not the tub assembly.

(2) Timing transponders and covers will be distributed by Officials prior to the first practice session for each Event. At the conclusion of each Event, each Entrant must return the timing transponder to Officials.

(3) The only INDYCAR approved substance which may be applied to the timing transponder cover is paint. No material may be added which may affect the timing transponder's ability to transmit a signal.

C. On Board Fire Equipment – Fire equipment provided by the chassis Manufacturer must remain in the designated locations during an Event.

D. Impact Recorder - All Cars must make provisions for the installation of an impact recorder securely bolted to the main chassis structure in a position determined by INDYCAR. The ADR download block must be mounted on the brake bias bracket inside the cockpit. Both LEDs and the connector must be visible from the Driver's view.

E. Mirrors –

(1) Mirrors must be used as supplied by the chassis Manufacturer.

(2) All Cars must be equipped with right and left side rearview mirrors in a fixed symmetrical position.

(3) The mirror must provide the Driver with maximum rearward and lateral vision.

(4) If a mirror assembly and/or glass comes off of a Car during an Event, the Car will not be permitted to continue in the Event until the mirror assembly and/or glass has been repaired or replaced and approved by INDYCAR.

F. Bodywork

(1) Radiator Inlets and Outlets (Oval Events Only) – Blanking covers are not permitted in any location within the radiator inlet or outlet ducts. A flat blanking cover may be constructed for the outside of the radiator sidepod exits. A cutout in the Engine compartment cooling duct may be added to the right and left sidepods (**See Illustration**). The cutout may be blocked by a flat panel when not in use.

Reference dimensions for radiator exit cutout

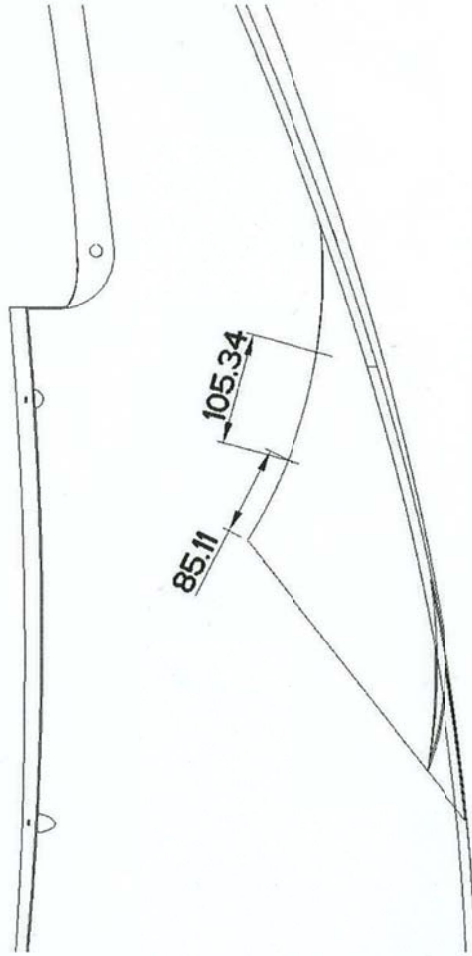

View from bottom

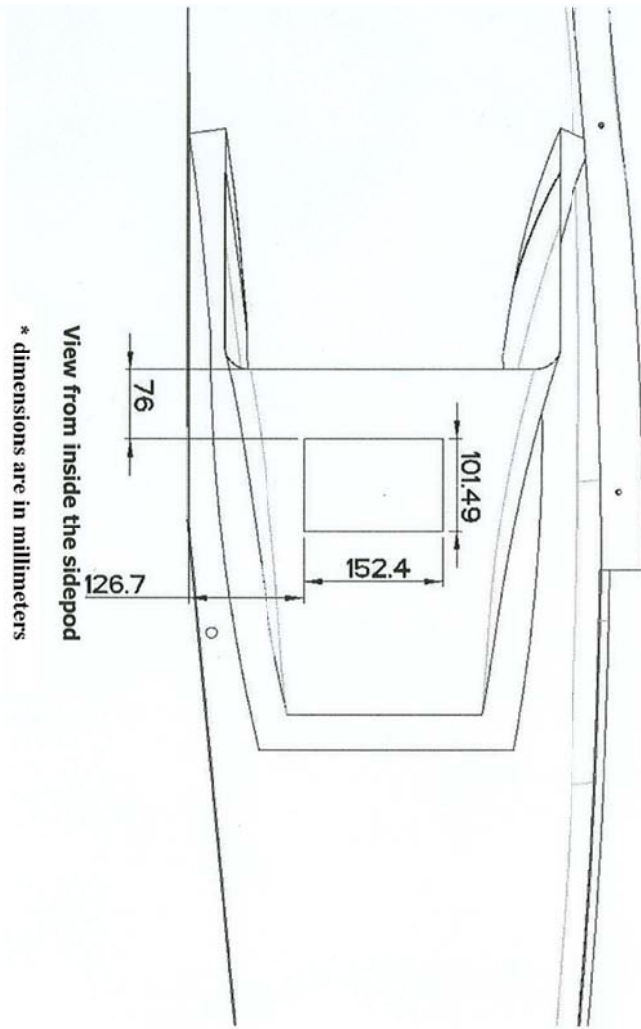

View from inside the sidepod
* dimensions are in millimeters

(2) Step Plane Height – Step plane height must be maintained from 1.575 inches to 1.7 inches (40.0 mm to 43.18 mm) as measured from the chassis reference plane. All floor stays must have a turnbuckle-type adjuster.

(3) Underwing – Other than clear coat, no painting/adhesive films or any other substances are permitted on the bottom surface of the underwing. Taping of seams, bracket holes and mounting bolt holes is permitted with the exception of the inspection holes.

(4) The underwing/Engine support bracket may be modified, provided it is made of steel and approved by INDYCAR.

G. Cockpit:

(1) The headrest must be in place during safety and technical inspection.

(2) All removable headrest pads must have the Manufacturer's tub number and Car number marked on the underside for identification purposes.

(3) Headrests must be attached by an INDYCAR supplied fastener.

H. Windscreen – Only windcreens supplied by the chassis Manufacturer may be used. They may be shortened or removed.

I. Seating System (See Illustration)

(1) Each seat must be manufactured for a specific Driver. Each seat must have a unique identification tag from the seat manufacturer and be date stamped.

(2) All seats must be inspected and approved by

Officials before use and will be subject to re-inspection by Officials at any time. INDYCAR may require a seat to be replaced.

(3) The Driver's seat must conform to the Driver's anatomy and be constructed of a material that will permit support and energy-attenuation both laterally and rearward. This material must fill as much of the cockpit under and to the side of the Driver as possible. The seating system must be in place when the Car is inspected.

(4) When the Driver is seated, there must be a smooth transition of energy-attenuating materials between the top of the seat and the cockpit rim padding, including the rear headrest. There must be no projections that could provide a fulcrum between the Driver's head and neck.

(5) Energy-attenuating materials must be used behind and alongside the Driver to absorb impact. At any point where the seat belts or shoulder straps pass through the seat or body structure of the Car, the edges must be rolled or have grommets to lessen the likelihood chafing or cutting of the belt and strap material.

(6) **Seat Belts** – An approved seat belt with a quick-release mechanism must be used. Both the fastening design and condition of the belt is subject to inspection by Officials. Life of the belts in use shall not exceed 2 years and must be date-stamped by the manufacturer. HANS® specific double-shoulder belts are permitted, provided they are mounted and used according to manufacturer specifications. All belts must conform to the following SFI Specifications: 3 inch SFI 16.1, 2 inch SFI 16.5.

(a) Seat belts must be worn in such a manner that they are tight and pass around the pelvis at a

point below the anterior superior iliac spines.

(b) Seat belts should not pass over the sides of the seat. They should come through the seat at the bottom on each side thereby wrapping and holding the pelvis over the greatest possible area.

(c) Five (5) or 6-point (crotch) belts must be connected to the main belt quick-release mechanism and securely attached to the chassis.

(d) Seat belts which have had to withstand a crash in excess of 50 Gs must be replaced.

(7) Shoulder Harness – Double over-the-shoulder straps must be used. Both the fastening design and condition of the straps is subject to inspection by Officials. Life of the straps in use shall not exceed 2 years and must be date-stamped by the manufacturer. Shoulder straps should be attached directly to a strong structural member of the chassis close behind the Driver's head and neck. At points of attachment, they should be 4 to 6 inches apart. They should be attached in a line approximately 90 degrees to the seat back and be approximately level with the top of the Driver's shoulders.

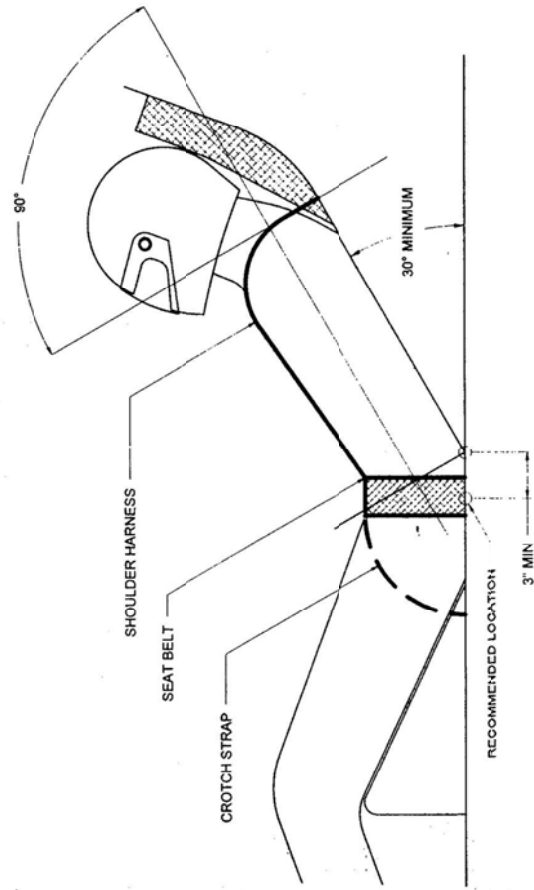

(8) Headrests

(a) Headrests must be used as supplied by the manufacturer. Modifications must be approved by INDYCAR before use. Headrests must be filled with an INDYCAR-approved material and fitted with INDYCAR-approved locking mechanisms. Headrests must form a smooth transition with the seat back and be fitted to the Driver with the Driver's head restraint system in place.

(b) All headrests must be inspected and approved by Officials before use and will be subject to confiscation and re-inspection by Officials at any time. Officials shall affix stickers to the headrests signifying approval for use. At any time, Officials may remove the approval stickers and require the headrests to be re-inspected and refurbished by an approved headrest repair station before INDYCAR may consider them for re-approval. The approved headrest repair stations are: Mark One Composites and JT Composites. The approved headrest repair station must submit to INDYCAR documentation stating that the headrest is approved for use in competition.

(c) Headrests must be attached by the 2011 INDYCAR-approved mechanism. The headrest must be in place during technical inspection.

(d) Additional Headrest Padding – Additional side padding must not exceed the height of the stock headrest as viewed from the side. Additional rear padding must not exceed the height or width of the headrest as viewed from the front. All padding must be contained in the original headrest dimensions as looked at in plan

view. The sides and rear of the additional headrest padding may consist of three pieces (left side, right sides and rear). The additional padding must be removable and independent of each other without the use of tools. All additional padding must be manufactured completely of foam and may have a single layer Kevlar backing that remains flexible and not interfere with the function of the stock headrest. Additional padding may not be taped along any surface. All additional pads and coverings must be inspected and approved prior to use.

(9) Roll Hoop - The height of the roll hoop must be 5 inches above the top of the Driver's helmet. (See **Illustration**).

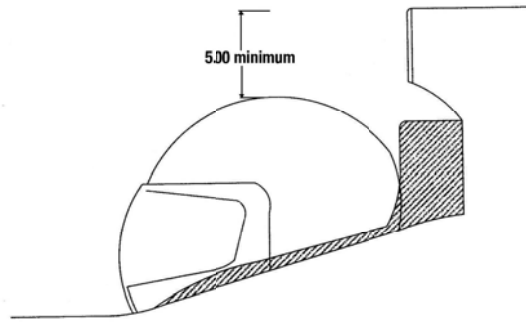

K. Car Tracking System, Telemetry and In-Car Cameras

(1) Car Tracking System - A car tracking system must be installed in the designated location(s) on each Car and must be operational at any time the Car is participating in Events unless otherwise notified by INDYCAR. The installation information is available from the INDYCAR office.

(2) Telemetry

(a) All Entrants shall install, operate, use and permit the use of broadcast telemetry equipment, video equipment, sound equipment, and data and other positioning and informational systems, equipment and data as directed by INDYCAR. Entrants shall not install, operate, use or permit the use of any broadcast telemetry equipment, video equipment, sound equipment, and data and other positioning and information systems, equipment and data other than as directed by INDYCAR.

(b) All Members shall provide INDYCAR and/or INDYCAR's broadcast licensees, Versus, Inc. ("Versus"), ESPN, Inc. ("ESPN") and American Broadcasting Companies, Inc. ("ESPN"), and their agents (together, the "Licensees") with access to all Cars for the purpose of installing equipment to collect, transmit, and record telemetry, video, sound, data and other information ("Licensee Equipment"). Such access shall include access for the purpose of operating, maintaining, updating, repairing, and/or replacing the Licensee Equipment. No Member shall remove, intentionally damage, or otherwise tamper with

the Licensee Equipment or permit any other individual to remove, intentionally damage or otherwise tamper with the Licensee Equipment. Entrants shall not distort, obscure or otherwise alter the telemetry, video, sound, data or other information. All Entrants shall assure that the following data regarding each Car is available for collection by the Licensee Equipment:

- (i) RPM
- (ii) Throttle Position
- (iii) Brake Pressure
- (iv) Gear
- (v) Steering Wheel Position
- (vi) Tire Temperature and/or Pressure
- (vii) Pressure Sensor on front of Car (if fitted)
- (viii) Fuel (to a degree of accuracy as specified by INDYCAR)
- (ix) GPS

(c) INDYCAR shall own any and all telemetry, video, sound, data or other information generated or collected as described and control the use and dissemination of the telemetry, video, sound, data or other information as described in Rule 1.2(F). This Rule does not apply to the extent any telemetry, video, sound, data or other information is generated by and contractually owned by a third party licensed or authorized by INDYCAR and its designees.

(3) In-Car Cameras - Each Car must install one or more in-car cameras in locations designated by INDYCAR if requested.

(a) Entrants are permitted to use their own on board video equipment, provided it is used during practice only, must be mounted from the roll hoop and is pre-approved by INDYCAR.

(b) Entrants must fit an INDYCAR approved camera housing.

14.5 Aerodynamics -

A. Configurations –

Low Downforce: Indianapolis, Front mainplane: 1.5 to 2.0 pos
Front flap: no
Rear mainplane: 1.5 to 2.0 pos
Rear flap: no
Rear wicker: .250 min
Set-up configuration: low downforce

Low Downforce: Kentucky
Front mainplane: 1.5 to 2.0 pos
Front flap: no
Rear mainplane: 1.5 to 2.0 pos
Rear flap: no
Rear wicker: .500 min
Set-up configuration: low downforce

High Downforce: Iowa
Front mainplane: 1.5 to 2.0 pos
Front flap: yes
Rear mainplane: 1.5 to 2.0 pos
Rear flap: yes, minimum 47 degrees
Rear wicker: .500 min
Set-up configuration: high downforce

All Road/Street Course:
Front mainplane: 1.5 to 2.0 pos
Front flap: yes
Rear mainplane: 1.5 to 2.0 pos
Rear flap: yes
Rear wicker: optional
Set-up configuration: Road/Street Course

B. Front and Rear Wing Assemblies - Only the secondary elements on the front and rear wing assemblies can be adjusted.

C. Front Wing –

(1) The front wing must not deflect more than 0.250 inches or less than 0.150 inches with a suspended load of a 100 lbs. to each outer end of the front wing.

(2) End fences cannot extend forward of the leading edge of the mainplane.

E. Wickers - Wickers are defined as follows:

(1) The rear vertical face of all wickers must be positioned on the trailing edge of the front and rear wing, front and rear wing secondary element and diffuser exits. Wickers must be manufactured from 6061 aluminum angle and must maintain a thickness of 0.062 inches. The transition point of all wickers must have no greater than a 0.010 inch radius. The vertical face of all wickers must be solid, rectangular in shape and maintained at a 90 degree angle to the wing at all times. The horizontal mounting surface of all wickers must be no more than 0.750 inches.

(2) Diffuser exit wickers must have a maximum length of 14 inches per side.

(3) Front wing secondary element wickers stamped 0.400 inches and 0.600 inches must be used as supplied by the chassis Manufacturer.

(4) Rear wing outer vertical end fence wickers are permitted. The maximum length is 6.750 inches, and the maximum height is 0.500 inches.

(5) Wickers are permitted on the front wing mainplane top trailing edge surface only. The

maximum length is 12 inches. Front wing mainplane top wickers are not permitted if the secondary element is utilized.

(6) Rear wing mainplane wickers are permitted on the top trailing edge surface only and must extend from end fence to end fence with no more than 0.030 inches clearance. Rear wing mainplane wickers are not permitted when the triple element set up is utilized. Rear wing flap wickers are permitted on the top side of the top element only. Rear wing flap wickers must extend from end fence to center support bracket and from center support bracket to end fence. No more than 0.030 inches total clearance is permitted. Rear wing flap wickers must be attached pursuant to the chassis Manufacturer specifications.

(7) Sidepod radiator exit wickers will be permitted. The maximum length is 12 inches, and the maximum height is 0.500 inches. Sidepod wickers must be attached pursuant to the chassis Manufacturer's specifications.

E. Wing Surfaces –

- (1) No painting, adhesive film or any other substance may be added to the lower wing surface from a point 1 inch behind the leading edge of the wing to the trailing edge of the wing.
- (2) Any substance applied to the top surface of the wing must extend under the wicker.

14.6 Suspension -

A. Springs - Only linear rate steel springs are permitted.

B. Front and Rear Dampers - The same make and type of damper assemblies as supplied with the Car must be retained (Koni part number 2812), except an option to the

Schrader valve is permitted.

Koni Parts:

Front Piston Rod	74.16.72.181.0
Rear Piston Rod	74.16.72.121.0
Piston	71.12.00.110.0
Piston Nut	71.25.00.161.0
Thrust Ring	71.10.07.370.0
Abutment Disc	71.10.07.267.0
Low Friction Quad Ring	16.04 8040 13
Lt. Wt. Aluminum	
Divider Floating Piston	71.12 1104 40
Lt. Wt. Aluminum Piston Nut	71.25.0016.30
Lt. Wt. Aluminum Piston	71.12.0011.00
Low Friction Rod Guide Complete	71.22.20.32.21
Lt. Wt. Aluminum Abutment Disc	71.10.0726.70
Shock Body	IPS-002
Shock Body	IPS-003
End Cap	IPS-001

C. Bump and rebound adjustment is permitted. Only approved valve assemblies may be used:

Standard	253-P54.17
Option	273-P273.3223.17
	233-P737.233.17
	235-P737.233.17
	257-P735.3222.17
	275-P737.3223.17
	259-P735.3222.17
	295-P737.3223.17
	237-P735.3222.17
	255-P737.2233.17
	277-P735.2333.17
	299-P735.3333.17

D. The length tolerances are:

Koni 2812 Front Shock

Overall Length 13.20 to 13.30 inches
 Stroke 2.00 inches
 Body to C/L of Mono 6.00 inches
 Eyelet to C/L of Mono 4.87 inches

Koni 2812 Rear Shocks

Overall Length 12.45 to 12.55 inches
 Stroke 3.00 inches
 Body to C/L of Mono 7.50 inches
 Eyelet to C/L of Mono 2.00 inches

E. Hydraulic Spring Perches – HyperCo/IPC hydraulic spring perches are permitted. Any other type or brand of spring perch must be approved by INDYCAR in writing before use.

F. Bump Rubbers and Packers – Bump rubbers and packers installed on damper shafts are permitted.

G. Push Rod Body Locations - Push rod body lengths must be used in the locations specified below:

Course	Location	Length
Oval	Front Left	23.90 or 24.25 inches
Oval	Front Right	24.25 inches
Road/ Street	Front Left	24.25 inches
Road/ Street	Front Right	24.25 inches
Oval	Rear Left	18.05 or 18.44 inches
Oval	Rear Right	18.44 inches
Road/ Street	Rear Left	18.44 inches
Road/ Street	Rear Right	18.44 inches

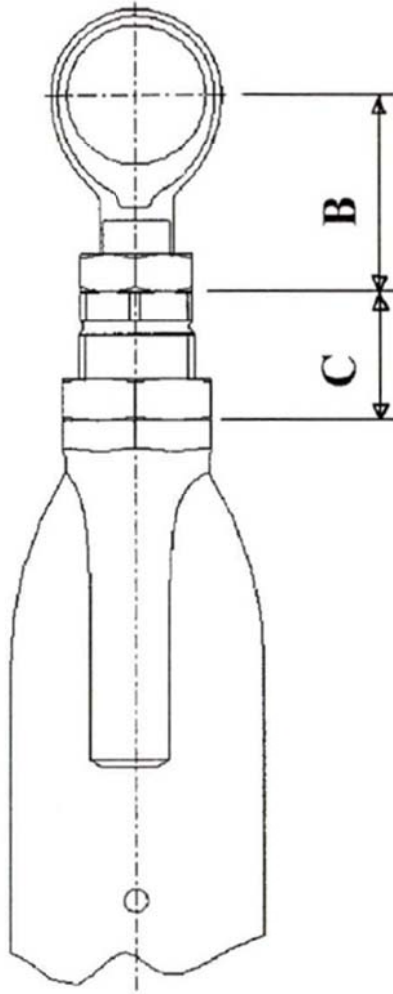

PUSH ROD BARREL

	MAX "C" [INCHES]	INNER THREAD	OUTER THREAD
FRONT	1.61	7/16 - 20 UNF LH	M20X2 RH
REAR	1.10	½ - 20 UNF LH	M20X2 RH

PUSH ROD CLEVIS

	MAX.B" [INCHES]	THREAD
FRONT LH	1.38	7/16 - 20 UNF LH
FRONT RH	1.38	7/16 - 20 UNF LH
FRONT LH	1.44	½ - 20 UNF LH
FRONT RH	1.44	½ - 20 UNF LH

H. Anti-Roll Bars - Anti-roll bars must be used as supplied by the chassis Manufacturer without modification. A cockpit adjustable front and rear anti-roll bar may be added with INDYCAR approval. The approved parts are:

- (a) Parallel 8mm
- (b) Tapered 13mm to 10mm
- (c) Tapered 8 mm to 4mm

I. Toe, Camber, and Castor Adjustment - The toe, camber and castor can be adjusted, provided they are within the chassis Manufacturer's original suspension specifications.

J. Weight Jacker - A manually adjustable mechanical weight jacker may be used, provided it is fitted to the right rear or right front wheel corner only. The maximum travel shall be 0.50 inches. Weight jackers may only be fitted for Oval Events.

K. Wishbone Bracket Studs – Six wishbone bracket studs are approved:

Part Number	Flange Width	Permitted Stud Location
IP2014005	0.078 (2mm)	Upper and Lower Rear Wishbones - Front and Rear Bracket
IP2014006	0.078 (2mm)	Upper and Lower Rear Wishbones - Front and Rear Bracket
IP2015027	0.236 (6mm)	Lower Rear Wishbones Only - Front and Rear Bracket
IP2015028	0.236 (6mm)	Lower Rear Wishbones Only - Front and Rear Bracket
IP2015012	0.236 (6mm)	Upper Rear Wishbones Only - Front and Rear Bracket
IP2015013	0.236 (6mm)	Upper Rear Wishbones Only - Front and Rear Bracket

14.7 Suspension Wheel/Wing Energy Management System (SWEMS) -

- A. Only approved SWEMS may be used.

- B. The SWEMS must be replaced:
 - a. If a Car sustains an impact on any of the 4 corners,
 - b. as required by INDYCAR

- C. All SWEMS must be covered with an INDYCAR-approved protective shield.
 - (1) Carbon fiber material may be used to cover the SWEMS running along the wishbone but cannot increase the wishbone tube thickness to a dimension of more than 0.750 inches and the wishbone tube width to a dimension of more than 2.400 inches. SWEMS covers must be symmetrical in section and attached in the same plane as the wishbone leg. (**See Illustrations.**) The profile of the SWEMS cover must be the same as the chassis Manufacturer's component.

 - (2) A carbon fiber cover must be used to cover the rear wing SWEMS. The only approved rear wing SWEMS covers are the standard Dallara SWEMS cover or Aerodine SWEMS cover part number ACT 11A00.

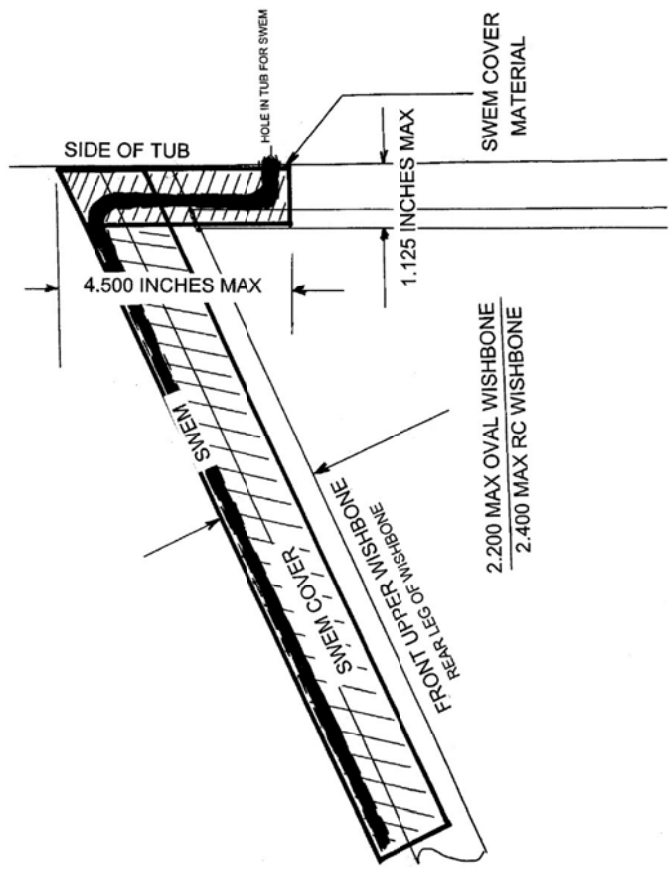

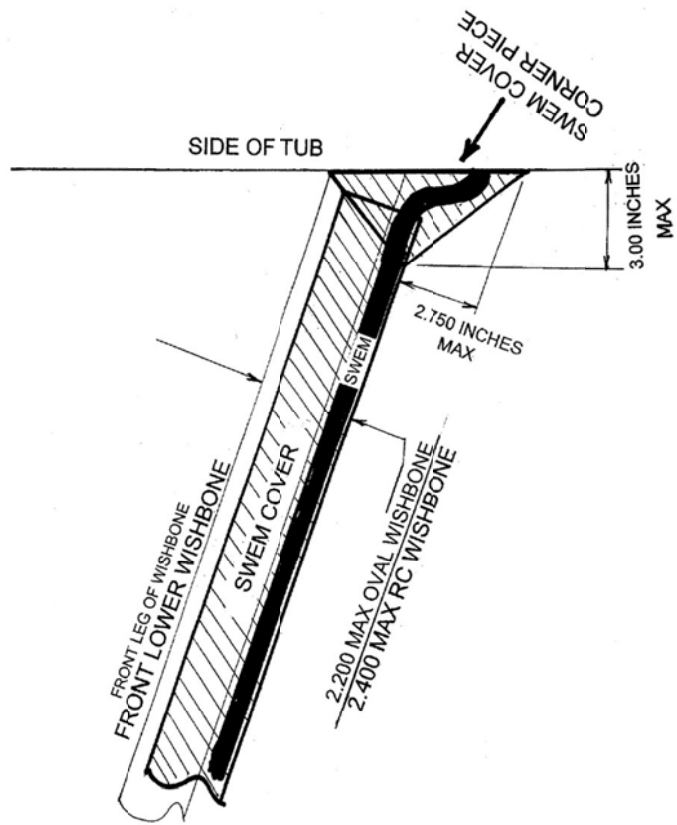

14.8 Brake Ducts, Brake Lines and Brakes -

A. Brake Ducts - Only tape, flat panels or panels that follow the leading edge contour of the brake duct may be used to regulate the airflow in the brake duct.

(1) Oval Events - Front and rear brake ducts are optional. Only front and rear brake ducts supplied by the chassis Manufacturer are permitted.

(2) Road/Street Course Events – Front and rear brake ducts are mandatory. Only brake ducts manufactured by the chassis Manufacturer may be used.

(3) Rotors must be used as supplied without modifications.

(4) Brake pads are unrestricted.

(5) AP is the only approved supplier of master cylinders.

(6) Stainless steel and/or -3 high pressure steel braided Teflon hose may be used for brake lines.

(7) Any devices to push or pull back caliper pistons are not permitted (e.g. pull back brakes).

14.9 Wheels – Only wheels approved by INDYCAR may be used. No modifications are permitted. Safety pin style wheel locks, MSC part #67973529 or an equivalent are mandatory. The only INDYCAR approved wheel finishes are Kephos and/or polished.

14.10 Tires -

A. Only tires provided by the tire Manufacturer and approved by INDYCAR may be used. The tires must be used in the designated location. No Entrant may sell, trade, or otherwise reassign tires to any other Entrant.

B. Each Entrant will be permitted a maximum number of sets of tires for use in each Event as follows:

Open Tests: 3 sets per Test

Oval Races: 3 sets per weekend

New Hampshire: One additional set of used tires must be used during the first 5 minutes of every practice session.

Indianapolis Race: 4 sets

Road/Street Course Races: 4 sets per weekend, including a maximum of 3 new sets.

Wet Tires: 3 sets per weekend. Wet tires may not be used prior to the Race without approval by the Race Director.

C. At the discretion of the tire manufacturer and INDYCAR, each Entrant may be allotted a maximum of 2 additional tires per Race weekend to be used if damage occurs.

D. Unused replacement tires returned to the mounting area will be credited to the Entrant's allotment.

E. Tire warmers are not permitted.

F. No substance may be applied to the tires.

G. An Entrant may use tires mounted at a previous Event during a subsequent Event, provided the Entrant receives approval from INDYCAR and the tires are included in the Entrant's allotment for the Event. Officials shall have the right to inspect tires and determine whether to approve or deny a request as they deem appropriate in their discretion. All such tires must be given to the tire Manufacturer to be stamped prior to use. Entrants are

required to return all tires at the completion of their life cycle to the tire Manufacturer.

H. Only nitrogen or compressed air may be used to inflate Tires.

14.11 Engine -

A. Only the Engine provided by the Engine builder and approved by INDYCAR may be used.

B. Only lubricants approved by the Engine builder may be used. No additives may be used.

C. Engine Idle - The idle speed of the Engine may be adjusted. No other adjustments are permitted.

D. Engine RPM – The maximum Engine RPM shall be as follows:

Oval Events – 8200 rpm

Road/Street Course Events – 8100 rpm

E. Oil Heaters – Only blanket-type oil heaters are permitted on the bell housing and transmission main case. Oil heaters may not be used during pre-qualifying staging and during pre-Race grid.

F. Alternator – The Engine alternator charging system must be connected.

G. ECU and Alternator Cooling – All Cars must be fitted with the chassis Manufacturer supplied alternator cooling ducts and 1 inch hose. All Cars must have a 0.250 inch wide by 4 inch high ECU cooling slot. The ECU and alternator cooling ducts must be installed pursuant to the chassis Manufacturer's installation specifications. (**See Illustration**).

* dimensions are in inches

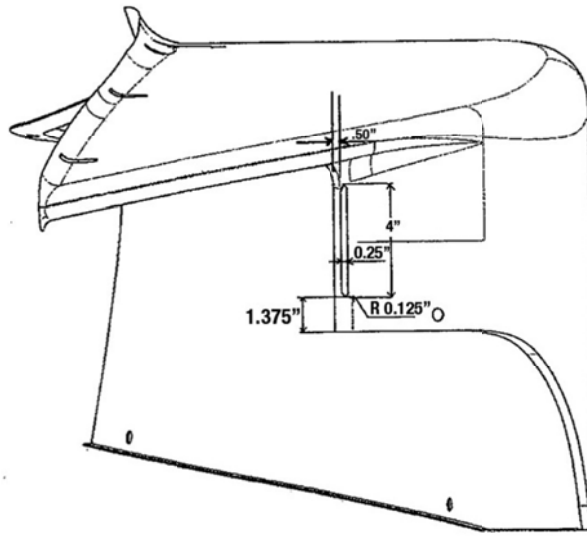

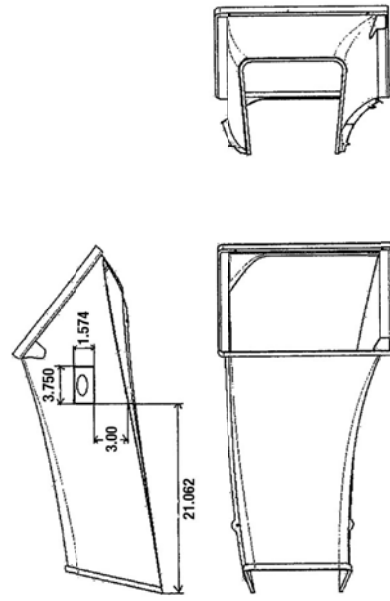

H. Airbox - No material or substance of any kind may be placed/added inside the upper or lower airbox. The upper airbox inlet plenum may have heat reflective material added externally. The upper airbox plenum must be fit to the lower airbox bolt pattern. No modifications are permitted to the upper or lower airbox.

I. Change/Repair of Engine – All Engine changes and/or repairs during an Event must have prior approval by INDYCAR and the Engine builder.

(1) Approved Engine changes consist of the following:

(a) The Engine has reached its pre-determined mileage limit or has insufficient miles remaining to complete one day's worth of on-Track activity; or

(b) The Engine has experienced a failure or condition deemed significant by INDYCAR and the Engine builder.

(2) Unapproved Engine changes include operation of the Engine outside of the Engine builder's guidelines. Unapproved changes shall result in a penalty including without limitation an Entrant's Car starting the Race from the rear of the starting grid or the Car not being permitted a qualifications attempt.

J. Oil Supply - Only Lucas Oil 10W40 supplied by INDYCAR may be used in an Engine.

K. Engine oil inlet tube part #PLMVAS001 must be used as supplied by the Engine builder.

L. Exhaust

(1) The exhaust system must be used as provided by the Engine builder. External and internal coating for heat reduction may be used.

(2) Each Car must use mufflers during Engine warm-up in the garage area.

(3) A tail pipe hanger bracket may be used, provided it is approved by INDYCAR prior to use.

14.12 Transmission –

A. Only transmission components and gear ratios provided by the chassis Manufacturer may be used without modification. They are as follows:

<i>INPUT GEAR</i>	<i>OUTPUT GEAR</i>	<i>GEAR</i>	<i>CWP 10/33</i>
<i>TEETH</i>	<i>TEETH</i>	<i>RATIO</i>	<i>MPH</i>
12	35	2.92	61.3
14	32	2.29	78.2
16	35	2.19	81.7
16	34	2.13	84.1
17	33	1.94	92.1
16	30	1.88	95.4
18	32	1.78	100.6
17	29	1.71	104.8
18	30	1.67	107.3
19	31	1.63	109.6
18	29	1.61	111.0
18	28	1.56	114.9
19	29	1.53	117.1
20	30	1.50	119.2
19	28	1.47	121.3
21	30	1.43	125.2
19	27	1.42	125.8
21	29	1.38	129.5
20	27	1.35	132.4
22	29	1.32	135.6
20	26	1.30	137.5

<i>INPUT GEAR</i>	<i>OUTPUT GEAR</i>	<i>GEAR</i>	<i>CWP 10/33</i>
<i>TEETH</i>	<i>TEETH</i>	<i>RATIO</i>	<i>MPH</i>
22	28	1.27	140.5
20	25	1.25	143.0
22	27	1.23	145.7
20	24	1.20	149.0
23	27	1.17	152.3
20	23	1.15	155.5
23	26	1.13	158.2
26	29	1.12	160.3
20	22	1.10	162.5
22	24	1.09	163.9
24	26	1.08	165.0
25	26	1.04	171.9
23	23	1.00	178.8
25	24	0.96	186.2
19	18	0.95	188.7
31	29	0.94	191.1
26	24	0.92	193.7
22	20	0.91	196.7
29	26	0.90	199.4
27	24	0.89	201.1

All Events - The only approved crown wheel and pinion is 10/33 manufactured by Ricardo. Rem polishing of the crown wheel, pinion and change gear set is permitted. Coatings of any type are not permitted. The transmission oil cooler mounting must remain as supplied by the chassis Manufacturer. The transmission cooler angle as measured from the chassis reference plane is 55 to 60 degrees.

Oval Events - First gear and reverse gear installation are optional. Gear ratios 2 thru 6 must be fitted.

Road/Street Course Events -

(1) The only approved differential assembly to be used is part number (IP2100429). It must be used as supplied by the transmission Manufacturer without modification. The clutch stack may be re-arranged, provided eight inner plates and six outer plates are used at all times. The only differential ramp approved for use is the supplied 80/45 ramp.

(2) Gear ratios 2 through 6 and reverse gear must be installed. First gear is optional.

14.13 Chassis Electronics -

A. Wire Loom – The system wire loom connectors 1 thru 3, 8 thru 20 and 22 must be connected to the sensors listed below at all times. The connectors on the system wire loom may be changed with prior INDYCAR approval.

- 1-Data Buddy Analogue
- 2-Data Buddy System
- 3-Gearbox – Gear Position Potentiometer
- 8-Steering Angle Potentiometer
- 9-Right Rear Damper
- 10-Left Rear Damper
- 11-Front Rocker Potentiometer
- 12-Front Rocker Potentiometer

13-Wheel Speed 2
14-Pi Communication
15-Dash Board
16-Wheel Speed 1
17-Beacon
18-Engine Split
19-Chassis Split
20-ADR 2
22-Ground Wire

B. The system wire loom connectors 4 thru 7 are not restricted. Only the sensors listed below are permitted for use in the non-restricted connectors. Only one sensor per connector is permitted. The connectors on the four free data acquisition channels may be changed with prior INDYCAR approval.

Right Front Ride Height Laser
Left Front Ride Height Laser
Rear Ride Height Laser
Right Front Push Rod Strain Gage
Left Front Push Rod Strain Gage
Right Rear Push Rod Strain Gage
Left Rear Push Rod Strain Gage
Brake pressure sensor located in either the front or rear brake line
Weight jacker position sensor
Gearbox temperature and gearbox pressure sensors

C. The only battery approved for use in the Engine is the Odyssey PC925. The battery must be attached by a holding bracket supplied by the Engine builder.

D. An optional master switch, Bosch part #034 100 1001, is permitted and available from the Engine builder.

E. The TCR and antenna must be mounted in the INDYCAR-designated location. The TCR dash light must be mounted in an INDYCAR approved location.

14.14 Fuel-Air -

- A.** Fuel must be used as supplied by INDYCAR.
- B.** The addition of any performance-enhancing substance to the fuel, air, or fuel/air mixture is not permitted.
- C.** All fuel is subject to testing at any time.
- D.** The fuel contained in the Car's fuel system must not be cooler than 5 degrees below ambient temperature.
- E.** Fueling is permitted in pit lane and in the fuel service area. Fuel may only be pumped out of a Car at the fuel service area or outside of Entrant's garage. During fueling operations, the Driver must not be in the Car. Fuel in the pit area must be in an approved container and stored behind the pit wall. All fuel containers must have a secure cap.
- F.** Fuel may not be stored in the Entrant's garage.
- G.** Local fire codes are a part of the Rules.

14.15 Pit Lane/Garage Area Fire Equipment - The Entrant must have a fully charged 10 pound dry powder extinguisher or its equivalent in the Car's pit/garage area. A gauge must be attached to each fire extinguisher.

14.16 Equipment -

- A.** The maximum height of the scoring stand is 84 inches measured from the ground to the top of the work surface. The maximum surface area of an awning is 50 square feet in plan view. INDYCAR in its discretion may determine if an Entrant may use an awning at a particular facility. Scoring stands using wheels or castors must be chocked or secured from moving, and awnings, flags, umbrellas or shields may be used, provided they do not block spectator viewing. Paint or other permanent markings may not be used in the garage, on the pit lane surface or on the pit

wall.

B. The maximum height of the transporter is 18 feet, including all railings, flags and viewing platforms.

C. Garages

(1) If garages are available, each Entrant shall receive a parking space and garage space limited by availability. INDYCAR in its discretion shall allocate a designated amount of space in the garage area for each Manufacturer.

(2) If garages are not available, each Entrant shall receive a maximum 30 ft. wide parking location in the garage area to use as a garage for the transporter and tent/awning, unless otherwise noted.